



ÖZDOĞAN
HIRDAVAT
Sanayi ve Ticaret Ltd. Şti.

freud

2025

KATALOG

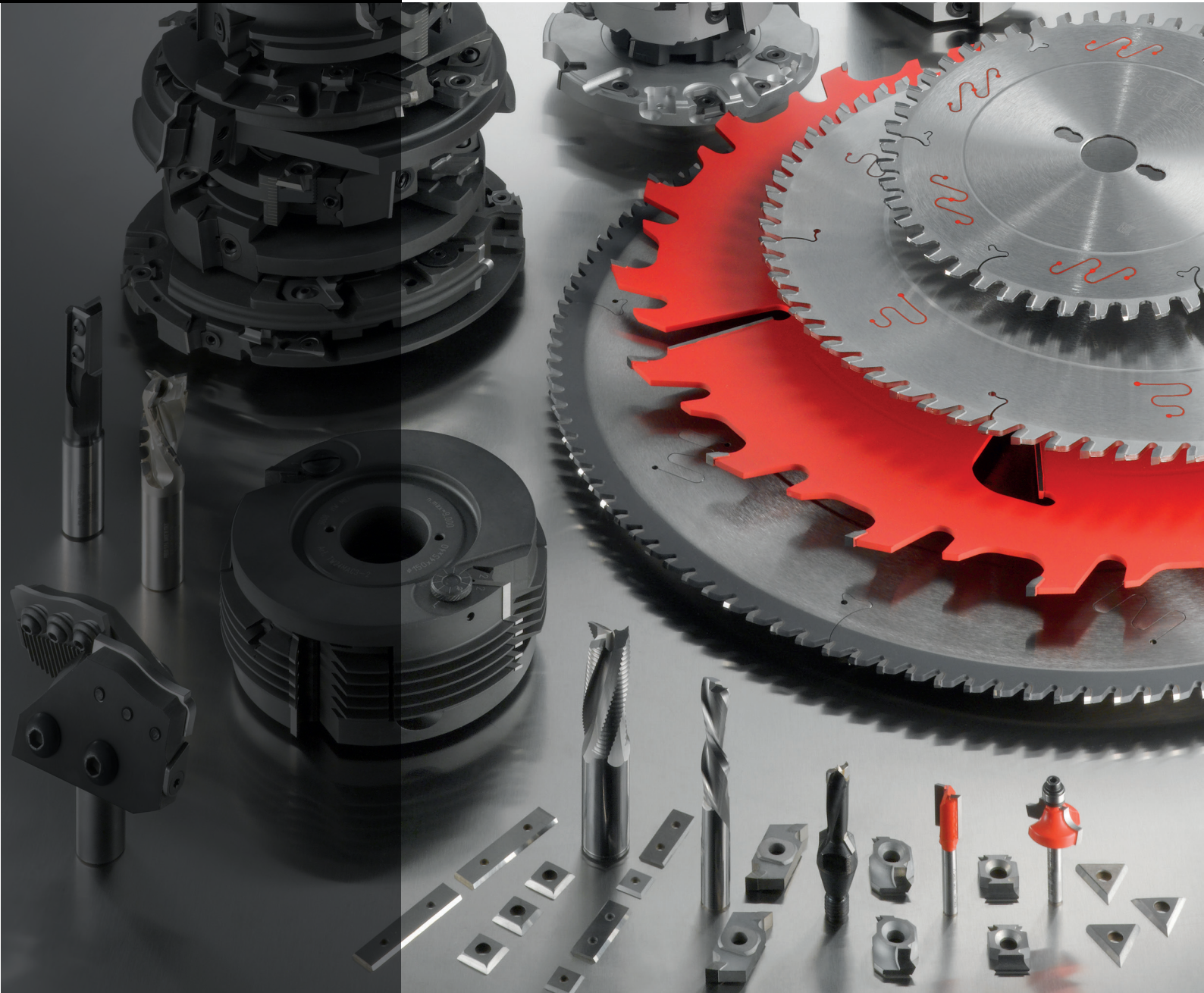

ÖZDOĞAN
HIRDAVAT
Sanayi ve Ticaret Ltd. Şti.

SUNTALAM & MDFLAM TESTERELERİ TRAPEZ DİŞ

Çizici testere ile çift lamine panelleri yüksek yüzey kalitesi ve uzun kesme ömrü ile detaylı melamin kaplamalı panelleri ölçülendirmek için.

Makineler:
Yatar makineler, yatay panel ebatlama makineleri
Özellikler:
Pozitif kesme açısına sahip trapez diş

Malzeme:
Çift lamine paneller

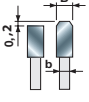

D mm	B mm	b mm	d mm	Z	a°	NL	MAKİNE/AÇIKLAMA	ÜRÜN KODU	FİYAT
200	3.2	2.2	30	64	5°	2/7/42	STANDART YATAR	LU3D 0100	4.316,00
220	3.3	2.2	20	64	5°	2/7/42	STANDART YATAR	LU3D 0201	5.341,00
250	3.2	2.2	30	80	5°	FT01	STANDART YATAR	LU3D 0400	4.886,00
300	3.2	2.2	30	96	5°	FT01	STANDART YATAR	LU3D 0600	6.137,00
350	3.5	2.5	30	108	5°	FT02	STANDART YATAR	LU3D 0900	7.897,00

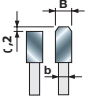
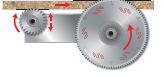

SUNTALAM & MDFLAM TESTERELERİ TRAPEZ DİŞ TEFLON KAPLAMA

Çizici testere ile çift lamine panelleri yüksek yüzey kalitesi ve uzun kesme ömrü ile detaylı melamin kaplamalı panelleri ölçülendirmek için.

Makineler:
Yatar makineler, yatay panel ebatlama makineleri
Özellikler:
Pozitif kesme açısına sahip trapez diş

Malzeme:
Çift lamine paneller



D mm	B mm	b mm	d mm	Z	a°	NL	MAKİNE/AÇIKLAMA	ÜRÜN KODU	FİYAT
250	3.2	2.2	30	80	5°	FT01	STANDART YATAR	LA92MT 003	4.479,00
300	3.2	2.2	30	96	5°	FT01	STANDART YATAR	LA92MT 001	5.441,00

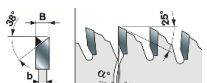
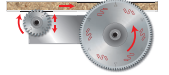

SUNTALAM & MDFLAM TESTERELERİ SİVRİ DİŞ

Çift lamine panelleri bir çizici testere kullanmadan her iki tarafa mükemmel yüzey kalitesi ile ölçülendirmek için.

Makineler:
Yatar makineler, dikey panel ebatlama makineleri, taşınabilir makineler
Özellikler:
ATB 38° diş

Malzeme:
Aşırı hassas kaplamalar, cilalı panellere sahip çift lamine paneller



D mm	B mm	b mm	d mm	Z	a°	NL	MAKİNE/AÇIKLAMA	ÜRÜN KODU	FİYAT
250	3.2	2.2	30	80	-2°	FT01	STANDART YATAR	LU3A 0200	5.320,00
300	3.2	2.2	30	96	2°	FT01	STANDART YATAR	LU3A 0300	6.535,00



Çizici gerekmez

OLUKLU TESTERE

Çizici testere kullanılmadan çift lamine panelleri yüksek yüzey kalitesi ve uzun kesme ömrü ile ölçülendirmek için.

Makineler:

Daire testereler, çizici testere olmayan yatay ve dikey makineler

Özellikler:

Negatif kesme açısına sahip oluklu diş

Malzeme:

Yapışkan ve sert kaplamalara sahip çift lamine paneller



D mm	B mm	b mm	d mm	Z	a°	NL	MAKİNE/AÇIKLAMA	ÜRÜN KODU	FİYAT
303	3.2	2.2	30	60	-5°	FT01	STANDART YATAR	LU3C 0300	7.524,00

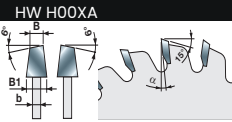

TEKLİ ÇİZİCİLER

Çift lamineli panellerde kaplamayı çizmek için.

Makineler:

Yatar makineler

Malzeme:

Çift lamine paneller



D mm	B mm	b mm	d mm	Z	a°	MAKİNE/AÇIKLAMA	ÜRÜN KODU	FİYAT
120	2.8-4.0	2.2	20	24	0°	STANDART YATAR	LI25M28 EA3	2.913,00
125	3.1-4.3	2.2	20	24	0°	STANDART YATAR	LI25M31 FA3	2.707,00
150	3.1-4.3	2.2	30	36	8°	SCM	LI25M31 KC3	4.194,00
180	3.4-4.6	2.2	25.4	36	8°	TÖRK	LI25M34 NR3	7.741,00

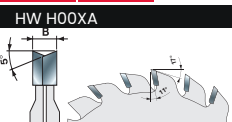

ÇİFTLİ ÇİZİCİLER

Çift lamineli panellerde kaplamayı çizmek için.

Makineler:

Yatar makineler

Malzeme:

Çift lamine suntalam veya mdf'lam

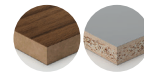

D mm	B mm	d mm	Z	a°	MAKİNE/AÇIKLAMA	ÜRÜN KODU	FİYAT
100	2.8-3.6	20	12+12	11°	MARTİN-SCHELLİNG	LI16M BA3	5.320,00
125	2.8-3.6	20	12+12	11°	STANDART YATAR	LI16M FA3	5.320,00

ATLAMALI AĞAÇ TESTERELERİ (SEYREK DİŞ)

Dilimleme için uygun testereler.

Makineler:
Yatar makineler, çoklu dilme makineleri
Özellikler:
ATB 10° diş, pozitif kesme açılı

Malzeme:
Yumuşak ve sert ağaç, ayrıca gevşek budaklı



D mm	B mm	b mm	d mm	Z	a°	NL	MAKİNE/AÇIKLAMA	ÜRÜN KODU	FİYAT
250	3.2	2.2	30	22	20°	FT01	STANDART YATAR	LU1C 0100	2.565,00
300	3.2	2.2	30	26	20°	FT01	STANDART YATAR	LU1C 0400	3.146,00
350	3.5	2.5	30	30	20°	2/10/60	STANDART YATAR	LU1C 1000	4.942,00
400	4.0	2.8	30	34	20°	2/10/60	STANDART YATAR	LU1C 1300	6.057,00

AĞAÇ TESTERELERİ

Boyuna ve enine kesim için uygun testereler

Makineler:
Yatar makineler, taşınabilir makineler
Özellikler:
Pozitif kesme açısına sahip ATB diş

Malzeme:
Yumuşak ve sert ağaç, işlenmemiş suntalam ve kontrplak



D mm	B mm	b mm	d mm	Z	a°	NL	MAKİNE/AÇIKLAMA	ÜRÜN KODU	FİYAT
150	3.2	2.2	30	48	5°	2/7/42	STANDART YATAR	LU2C 0100	2.917,00
180	3.2	2.2	30	56	5°	2/7/42	STANDART YATAR	LU2C 0400	3.340,00
250	3.2	2.2	30	48	10°	FT01	STANDART YATAR	LU2B 0500	3.697,00
250	3.2	2.2	30	60	10°	FT01	STANDART YATAR	LU2B 0700	4.135,00
250	3.2	2.2	30	80	5°	FT01	STANDART YATAR	LU2C 1200	4.904,00
300	3.2	2.2	30	48	15°	FT01	STANDART YATAR	LU2A 2100	4.240,00
300	3.2	2.2	30	60	10°	FT01	STANDART YATAR	LU2B 0900	4.617,00
300	3.2	2.2	30	72	10°	FT01	STANDART YATAR	LU2B 1100	5.016,00
300	3.2	2.2	30	96	5°	FT01	STANDART YATAR	LU2C 1500	5.810,00
350	3.5	2.5	30	54	15°	FT02	STANDART YATAR	LU2A 2800	5.753,00
350	3.5	2.5	30	72	10°	FT02	STANDART YATAR	LU2B 1400	6.462,00
350	3.5	2.5	30	84	10°	FT02	STANDART YATAR	LU2B 1600	6.890,00
400	4.0	2.8	30	60	15°	2/10/60	STANDART YATAR	LU2A 3300	9.228,00
400	4.0	2.8	30	96	10°	2/10/60	STANDART YATAR	LU2B 1900	10.007,00
400	3.8	2.8	30	120	5°	2/10/60	OPTICUT KESİM	LU2C 2100	10.439,00
450	4.4	3.0	30	54	15°	2/10/60	STANDART YATAR	LU2A 3500	11.219,00
500	4.4	3.2	30	60	15°	2/10/60-80	STANDART YATAR	LU2A 3700	13.204,00
500	4.4	3.2	30	144	5°	2/10/60-80	OPTICUT KESİM	LU2C 2300	16.392,00

İNCE AĞAÇ TESTERELERİ

Boyuna ve enine kesim için uygun testereler. Düşük kesme yüksekliği iş parçası beslemesini kolaylaştırır.

Makineler:
Yatar makineler, taşınabilir makineler
Özellikler:
15° diş, pozitif kesme açılı

Malzeme:
Yüksek kaliteli, yumuşak ve sert ağaç



D mm	B mm	b mm	d mm	Z	a°	NL	MAKİNE/AÇIKLAMA	ÜRÜN KODU	FİYAT
180	1.5	1.0	30	40	15°	2/7/42	GÖNYELEME YATAR	LU1H 0100	2.667,00
200	1.5	1.0	30	60	15°	2/7/42	GÖNYELEME YATAR	LU1H 0400	3.681,00
250	2.2	1.6	30	24	15°	FT01	STANDART YATAR	LCL5M 02019	2.609,00
250	2.5	1.6	30	24	15°	FT01	STANDART YATAR	LU1E 0100	2.652,00
250	2.5	1.6	30	48	15°	FT01	GÖNYELEME YATAR	LU1H 0700	3.485,00
250	2.5	1.6	30	60	15°	FT01	GÖNYELEME YATAR	LU1H 0800	4.065,00
300	2.7	1.8	30	28	15°	FT01	STANDART YATAR	LU1E 0300	3.609,00
350	3.0	2.2	30	32	15°	FT01	STANDART YATAR	LU1E 0400	4.492,00
350	3.0	2.2	30	84	15°	FT01	GÖNYELEME YATAR	LU1H 1300	6.391,00

45° KESİM TESTERELERİ

Enine kesim için uygun. Parçalanma olmadan mükemmel kesime sahip yüksek performanslı testere.

Makineler:

Tek ve çift kafalı gönye testereler

Özellikler:

Düz ATB 15° diş, aksenal 15° ve pozitif kesme açısı ile

Malzeme:

Yumuşak, sert ağaç, MDF ve Pleksiglas

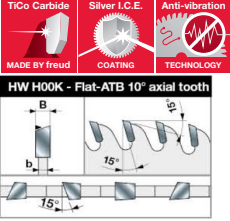

D mm	B mm	b mm	d mm	Z	a°	NL	MAKİNE/AÇIKLAMA	ÜRÜN KODU	FİYAT
300	3.0	2.2	30	100	15°	FT01	S.YATAR/GÖNYE KESME	LU1L 0500	6.173,00
300	3.0	2.2	30	120	15°	FT01	S.YATAR/GÖNYE KESME	LU1L 0600	6.420,00
305	3.0	2.2	30	100	15°		S.YATAR/GÖNYE KESME	LU1L 1100	6.173,00
350	3.45	3.0	30	108	10°	FT02	S.YATAR/GÖNYE KESME	LU1I 0900	8.158,00
350	3.0	2.2	30	120	15°	FT01	S.YATAR/GÖNYE KESME	LU1L 0900	8.071,00

ÇOKLU DİLME TESTERELERİ

Dilme için uygun testereler.

Makineler:

Çoklu dilme makineleri

Özellikler:

ATB 10° diş

Malzeme:

%15 nem oranında kurutulan yumuşak ve sert ağaç

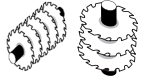
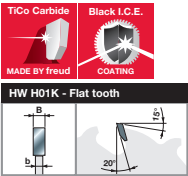

D mm	B mm	b mm	d mm	Z	a°	NL	MAKİNE/AÇIKLAMA	ÜRÜN KODU	FİYAT
250	3.2	2.2	70	20+2+2	20°		ÇOKLU DİLİMLEME	LM04 25003	5.250,00
300	3.2	2.2	70	24+2+2	20°		ÇOKLU DİLİMLEME	LM04 30003	6.450,00
300	3.2	2.2	75	24+2+2	20°		ÇOKLU DİLİMLEME	LM04 30005	6.450,00
350	3.5	2.5	70	28+2+4	20°		ÇOKLU DİLİMLEME	LM04 35005	7.950,00
350	3.5	2.5	75	28+2+4	20°		ÇOKLU DİLİMLEME	LM04 35010	7.950,00
400	4.0	2.8	70	28+2+4	20°		ÇOKLU DİLİMLEME	LM04 40002	9.850,00
400	4.0	2.8	75	28+2+4	20°		ÇOKLU DİLİMLEME	LM04 40004	9.850,00



ÇOKLU DİLME TESTERELERİ

Dilme için uygun testereler.

Makineler:

Çoklu dilme makineleri

Özellikler:

ATB 10° diş

Malzeme:

%15 nem oranında kurutulan yumuşak ve sert ağaç

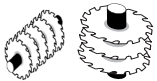
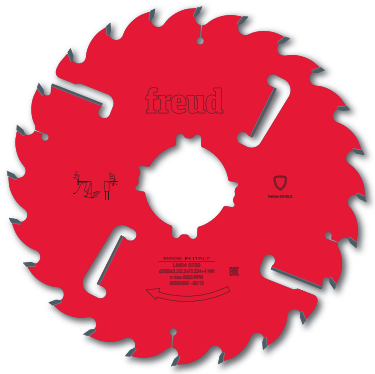

D mm	B mm	b mm	d mm	Z	a°	NL	MAKİNE/AÇIKLAMA	ÜRÜN KODU	FİYAT
250	3.2	2.2	70	20+2+2	20°		ÇOKLU DİLİMLEME	LM04 0300	4.560,00
300	3.2	2.2	70	24+2+2	20°		ÇOKLU DİLİMLEME	LM04 0700	5.500,00
300	3.2	2.2	75	24+2+2	20°		ÇOKLU DİLİMLEME	LM04 0701	5.500,00
350	3.5	2.5	70	28+2+4	20°		ÇOKLU DİLİMLEME	LM04 1300	6.800,00
350	3.5	2.5	75	28+2+4	20°		ÇOKLU DİLİMLEME	LM04 1302	7.080,00
400	4.0	2.8	70	28+2+4	20°		ÇOKLU DİLİMLEME	LM04 1600	8.520,00
400	4.0	2.8	75	28+2+4	20°		ÇOKLU DİLİMLEME	LM04 1601	8.520,00

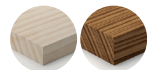

LSBX PANEL EBATLAMA TESTERELERİ

Tekli veya çoklu panelleri ölçülendirmek için

Makineler:

CNC Panel Ebatlama Makineleri için

Özellikler:

Pozitif kesme açısına sahip trapez diş

Malzeme:

Suntalam, MDFlam, Kompakt Laminant, Termoplastik Kompozitler ve Pleksiglas

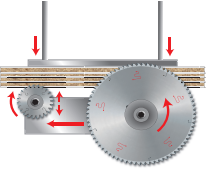
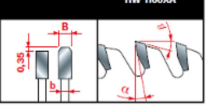

D mm	B mm	b mm	d mm	Z	a°	NL	MAKİNE/AÇIKLAMA	ÜRÜN KODU	FİYAT
300	4.4	3.0	30	60	15°	2/10/60	TURANLAR	LSB30001X	9.518,00
300	4.4	3.0	30	72	15°	2/10/60	TURANLAR	LSB30005X	10.159,00
320	4.4	3.2	65	72	15°	2/9/110, 2/9/95	SELCO, AYZA MIZRAK	LSB32001X	11.711,00
320	4.4	3.2	75	72	15°	3/13/95, 3/7/100	GIBEN, TÖRK	LSB32002X	11.711,00
320	4.4	3.2	30	72	15°	2/10/60, 2/13/94	MAYER, AES	LSB32009X	11.711,00
350	4.4	3.2	30	72	15°	2/10/60	HOLZER, MAYER	LSB35003X	11.572,00
350	4.4	3.2	60	72	15°	2/14/100	HOLZMA	LSB35004X	11.572,00
350	4.4	3.2	80	72	15°	4/9/100, 2/9/110, 2/14/110	GABBIANI	LSB35005X	11.572,00
350	4.4	3.2	50	72	15°	4/13/80	GIBEN	LSB35006X	12.418,00
355	4.4	3.2	30	72	15°	2/10/60	HOLZER, MAYER	LSB35504X	12.418,00
355	4.4	3.2	75	72	15°	4/15/105, 2/7/110	GIBEN, KDT, HOLD	LSB35505X	12.418,00
355	4.4	3.2	75	72	15°	3/7/100	MATMAZZE, GABBIANI	LSB35507X	12.418,00
360	4.4	3.2	65	72	15°	2/9/110, 2/9/95	SELCO, AYZA MIZRAK	LSB36002X	12.714,00
360	4.4	3.2	30	72	15°	2/13/94	SHELLING	LSB36003X	12.714,00
380	4.4	3.2	60	72	15°	2/14/100	HOLZMA	LSB38002X	13.986,00
380	4.8	3.5	60	72	15°	2/14/100	HOLZMA	LSB38004X	14.622,00
380	4.8	3.5	60	84	15°	2/14/100	HOLZMA	LSB38005X	14.973,00
380	4.4	3.2	50	72	15°	4/13/80	GIBEN	LSB38008X	12.849,00
380	4.4	3.2	80	72	15°	4/9/100, 2/9/110, 2/14/110	GABBIANI	LSB38010X	12.849,00
380	4.4	3.2	30	72	15°	2/8/83, 2/10/60		LSB38011X	12.849,00
380	4.4	3.2	75	72	15°	2/14/100	HOLZMA	LSB38012X	12.849,00
380	4.4	3.2	80	96	15°	4/9/100, 2/9/110, 2/14/110	GABBIANI	LSB38013X	15.115,00
380	4.4	3.2	65	72	15°	2/9/110	SELCO	LSB38014X	12.849,00
400	4.4	3.2	30	72	15°	2/10/60, 2/13/94	HOLZER, SCHEER, AES, SCHELLING	LSB40007X	13.204,00
400	4.4	3.2	75	72	15°	4/15/105, 2/7/110, 2/14/100	GIBEN, SAWTECH, KDT	LSB40008X	13.204,00
400	4.4	3.2	80	72	15°	2/15/105, 2/9/130, 4/19/120	SELCO	LSB40009X	13.204,00
400	4.4	3.2	80	72	15°	4/9/100, 2/9/110, 2/14/110, 2/14/125	GABBIANI, TURANLAR	LSB40012X	13.204,00
400	4.4	3.2	65	72	15°	2/9/110	SELCO	LSB40016X	13.204,00
420	4.8	3.5	60	84	15°	2/14/100, 2/14/125	HOLZMA	LSB42002X	18.811,00
430	4.4	3.2	30	72	15°	2/13/94	AES	LSB43007X	16.607,00
430	4.4	3.2	75	72	15°	4/15/105, 2/7/110	GIBEN	LSB43008X	14.763,00
430	4.4	3.2	80	72	15°	2/9/130, 2/14/110, 4/19/120	SELCO, GABBIANI	LSB43009X	14.973,00
430	4.4	3.2	65	72	15°	2/9/110	SELCO	LSB43012X	14.835,00
450	4.4	3.2	30	72	15°	2/10/60, 2/14/95	MAYER	LSB45007X	16.195,00
450	4.4	3.2	80	72	15°	2/9/130, 2/14/110, 4/19/120	SELCO, GABBIANI	LSB45009X	16.195,00
450	4.8	3.5	30	72	15°	2/9/60	SCHEER	LSB45016X	16.522,00
450	4.8	3.5	60	72	15°	2/14/125, 2/17/100	HOLZMA, NANXING	LSB45017X	16.522,00
450	4.8	3.5	80	72	15°	2/9/130, 4/19/120, 2/14/125	SELCO	LSB45018X	16.522,00
450	4.8	3.5	60	84	15°	2/14/125	HOLZMA	LSB45019X	18.806,00
450	4.8	3.5	75	72	15°	2/7/110	KDT	LSB45020X	17.388,00
460	4.4	3.2	30	72	15°	2/13/94	SCHELLING	LSB46001X	17.388,00
470	4.4	3.2	75	96	15°	4/15/105	GIBEN	LSB47004X	23.415,00
470	4.8	3.5	70	72	15°	4/11/130	SELCO	LSB47005X	19.661,00
520	4.8	3.5	60	72	15°	2/11/115, 2/19/120	HOLZMA	LSB52003X	21.115,00
520	4.8	3.5	70	72	15°	4/11/130	SELCO	LSB52006X	21.115,00
520	4.8	3.5	30	72	15°	2/13/94	SCHELLING	LSB52007X	21.115,00
600	5.8	4.0	60	72	15°	2/11/115, 2/19/120	HOLZMA	LSB60002X	26.537,00

Lİ25 PANEL EBATLAMA ÇİZİCİLERİ

Çift lamineli panellerde kaplamayı çizmek için

Makineler:

CNC Panel Ebatlama Makineleri için

Özellikler:

ATB 6° dış pozitif kesme açılı

Malzeme:

Çift lamine suntalam ve mdflam

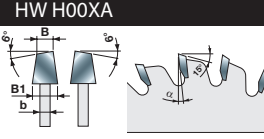

D mm	B mm	b mm	d mm	Z	a°	NL	MAKİNE/AÇIKLAMA	ÜRÜN KODU	FİYAT
125	4.3-5.5	3.2	20	24	0°		GABBIANI, PANHANS	Lİ25M43 FA3	4.620,00
125	4.3-5.5	3.2	45	24	0°		GIBEN, HOMAG	Lİ25M43 FE3	4.620,00
150	4.3-5.6	3.2	30	36	8°		SCM, TURANLAR	Lİ25M43 KC3	5.890,00
150	4.3-5.6	3.2	45	36	8°		SCM, HOLZMA, HOMAG	Lİ25M43 KE3	5.890,00
160	4.3-5.5	3.2	45	36	8°	3/11/70	GIBEN	Lİ25M43 LE3	6.250,00
160	4.3-5.5	3.2	55	36	8°	3/6/84, 3/7/66	GABBIANI, TÖRK	Lİ25M43 LG3	6.250,00
180	4.3-5.5	3.2	30	28	8°	2/7/42, 2/10/60	HOLZER	Lİ25M43 NC3	5.900,00
180	4.3-5.5	3.2	30	36	8°	2/7/42, 2/10/60	HOLZER	Lİ25M43 XN3	6.470,00
180	4.3-5.5	3.2	45	36	8°		HOLZMA	Lİ25M43 NE3	6.470,00
180	4.3-5.5	3.2	50	36	8°	3/13/80	GIBEN	Lİ25M43 NF3	6.470,00
180	4.7-5.9	3.5	45	36	8°		HOLZMA	Lİ25M47 NE3	7.050,00
200	4.3-5.5	3.2	20	36	8°	2/11/66, 2/10/60, 2/9/62	SCHELLING, AES	Lİ25M43 PA3	6.390,00
200	4.3-5.5	3.2	30	36	8°	2/9/60, 2/10/60	SCHEER	Lİ25M43 PC3	6.390,00
200	4.3-5.5	3.2	45	36	8°		HOLZMA	Lİ25M43 PE3	6.390,00
200	4.3-5.5	3.2	50	36	8°	2/7/80, 3/13/80	GIBEN, SAWTECH	Lİ25M43 PF3	6.890,00
200	4.3-5.5	3.2	65	36	8°	2/9/100, 2/9/110	SELCO	Lİ25M43 PI3	6.890,00
200	4.3-5.5	3.2	80	36	8°	2/14/110	GABBIANI, SCM	Lİ25M43 PL3	6.890,00
200	4.7-5.9	3.5	20	36	8°	2/11/66	SCHELLING	Lİ25M47 PA3	7.080,00
200	4.7-5.9	3.5	45	36	8°		HOLZMA	Lİ25M47 PE3	7.080,00
200	4.7-5.9	3.5	50	36	8°	2/7/80	KDT	Lİ25M47 PF3	7.380,00
200	4.7-5.9	3.5	65	36	8°	2/9/100, 2/9/110	SELCO	Lİ25M47 PI3	7.380,00
200	5.7-6.9	4.0	45	36	8°		HOLZMA	Lİ25M57 PE3	7.580,00
215	4.3-5.5	3.2	50	42	8°	2/7/80, 3/15/80	GIBEN	Lİ25M43 QF3	9.160,00
300	4.3-5.5	3.2	65	72	12°	2/9/110, 2/9/100	SELCO	Lİ25M43 RI3	12.100,00
300	4.3-5.5	3.2	80	72	12°	2/14/110	GABBIANI	Lİ25M43 RL3	12.100,00

JİLET BIÇAKLAR

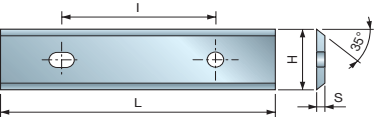
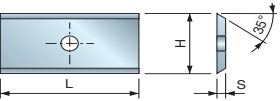
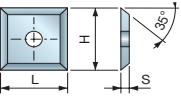

L mm	H mm	S mm	l mm	KESKİN TARAF	MAKİNE/AÇIKLAMA	ÜRÜN KODU	FİYAT
7.6	12	1.5		2 TARAFAI KESKİN	FREZE JİLETİ	CG08M AA310	107,30
12	12	1.5		4 TARAFAI KESKİN	FREZE JİLETİ	CG08M BA310	116,70
14	14	2.0		4 TARAFAI KESKİN	FREZE JİLETİ	RG01M AA310	168,10
15	12	1.5		2 TARAFAI KESKİN	FREZE JİLETİ	CG08M CA310	133,40
20	12	1.5		2 TARAFAI KESKİN	FREZE JİLETİ	CG08M DA310	114,50
30	12	1.5	14	2 TARAFAI KESKİN	FREZE JİLETİ	CG08M EA310	147,80
40	12	1.5	26	2 TARAFAI KESKİN	FREZE JİLETİ	CG08M LA310	231,90
50	12	1.5	26	2 TARAFAI KESKİN	FREZE JİLETİ	CG08M FA310	192,80
50	12	1.5	26	4 TARAFAI KESKİN	FREZE JİLETİ	CG71M AA310	650,70
60	12	1.5	26	2 TARAFAI KESKİN	FREZE JİLETİ	CG08M GA310	288,40

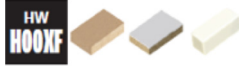

L mm	H mm	S mm	l mm	KESKİN TARAF	MAKİNE/AÇIKLAMA	ÜRÜN KODU	FİYAT
30	12	1.5	14	2 TARAFAI KESKİN	FREZE JİLETİ	CG20M EA310	198,60
50	12	1.5	26	2 TARAFAI KESKİN	FREZE JİLETİ	CG20M FA310	250,70

L mm	H mm	S mm	R	KESKİN TARAF	MAKİNE/AÇIKLAMA	ÜRÜN KODU	FİYAT
14	14	2.0	150	4 TARAFAI KESKİN	FREZE JİLETİ	RR10M AA310	231,90

EL TİPİ DAİRE TESTERE MAKİNELERİ İÇİN AHŞAP KESİM TESTERELERİ

freud

Makiner: Portatif el tipi daire testere makineleri için
Özellikler: Pozitif kesim açısına sahip ATB (sağ-sol) diş

Malzeme: Yumuşak ve sert ağaç, sunta, mdf, kontrplak



D mm	B mm	b mm	d mm	Z	a°	MAKİNE/AÇIKLAMA	ÜRÜN KODU	FİYAT
160	2.4	1.6	16	24	15°	EL TİPİ DAİRE TESTERE MAKİNELERİ	FR06W 001H	1.871,00
160	2.4	1.6	20	24	15°	EL TİPİ DAİRE TESTERE MAKİNELERİ	FR06W 009H	1.871,00
160	2.4	1.6	20	48	5°	EL TİPİ DAİRE TESTERE MAKİNELERİ	FR06W 011H	2.034,00
165	2.4	1.6	20	24	15°	EL TİPİ DAİRE TESTERE MAKİNELERİ	FR07W 003H	1.967,00
180	2.4	1.6	30	24	15°	EL TİPİ DAİRE TESTERE MAKİNELERİ	FR09W 003H	2.022,00
180	2.4	1.6	30	48	5°	EL TİPİ DAİRE TESTERE MAKİNELERİ	FR09W 004H	2.120,00
184	2.4	1.6	16	40	10°	EL TİPİ DAİRE TESTERE MAKİNELERİ	FR11W 002H	2.310,00
184	2.4	1.6	30	24	15°	EL TİPİ DAİRE TESTERE MAKİNELERİ	FR11W 007H	2.094,00
190	2.4	1.6	30	24	15°	EL TİPİ DAİRE TESTERE MAKİNELERİ	FR13W 006H	1.908,00
190	2.4	1.6	30	40	10°	EL TİPİ DAİRE TESTERE MAKİNELERİ	FR13W 007H	2.446,00
190	2.4	1.6	30	48	10°	EL TİPİ DAİRE TESTERE MAKİNELERİ	FR13W 008H	2.310,00
210	2.4	1.8	30	24	15°	EL TİPİ DAİRE TESTERE MAKİNELERİ	FR15W 003H	2.007,00
210	2.4	1.8	30	40	15°	EL TİPİ DAİRE TESTERE MAKİNELERİ	FR15W 001H	2.560,00
210	2.4	1.8	30	48	10°	EL TİPİ DAİRE TESTERE MAKİNELERİ	FR15W 004H	2.462,00
230	2.8	1.8	30	24	15°	EL TİPİ DAİRE TESTERE MAKİNELERİ	FR19W 001H	2.133,00
230	2.8	1.8	30	36	15°	EL TİPİ DAİRE TESTERE MAKİNELERİ	FR19W 002H	2.783,00
230	2.8	1.8	30	48	15°	EL TİPİ DAİRE TESTERE MAKİNELERİ	FR19W 003H	2.689,00
235	2.8	1.8	30	48	15°	EL TİPİ DAİRE TESTERE MAKİNELERİ	FR20W 005H	3.157,00

GÖNYE KESME MAKİNELERİ İÇİN AHŞAP KESİM TESTERELERİ

freud

Makiner: Gönye kesme makineleri için
Özellikler: Negatif kesim açısına sahip ATB (sağ-sol) diş

Malzeme: Yumuşak ve sert ağaç, sunta, mdf, kontrplak



D mm	B mm	b mm	d mm	Z	a°	MAKİNE/AÇIKLAMA	ÜRÜN KODU	FİYAT
260	2.6	1.8	30	60	10°	GÖNYE KESME MAKİNELERİ	FR26W 001T	4.633,00

EL TİPİ DAİRE TESTERE MAKİNELERİ İÇİN ÇİVİLİ AHŞAP KESİM TESTERELERİ

freud

Makiner: Portatif el tipi daire testere makineleri için
Özellikler: Pozitif kesim açısına sahip ATB (sağ-sol) diş

Malzeme: Çivili ahşap, sunta



D mm	B mm	b mm	d mm	Z	a°	MAKİNE/AÇIKLAMA	ÜRÜN KODU	FİYAT
160	2.0	1.3	20	14	18°	EL TİPİ DAİRE TESTERE MAKİNELERİ	FR06C 001H	1.639,00
165	2.0	1.3	20	14	18°	EL TİPİ DAİRE TESTERE MAKİNELERİ	FR07C 001H	1.697,00
180	2.0	1.3	30	14	18°	EL TİPİ DAİRE TESTERE MAKİNELERİ	FR09C 001H	1.773,00
184	2.0	1.3	16	14	18°	EL TİPİ DAİRE TESTERE MAKİNELERİ	FR11C 001H	1.851,00
190	2.0	1.3	30	14	18°	EL TİPİ DAİRE TESTERE MAKİNELERİ	FR13C 001H	1.950,00
210	2.0	1.3	30	16	18°	EL TİPİ DAİRE TESTERE MAKİNELERİ	FR15C 001H	2.157,00
230	2.2	1.6	30	20	18°	EL TİPİ DAİRE TESTERE MAKİNELERİ	FR19C 001H	2.505,00
235	2.2	1.6	30	20	18°	EL TİPİ DAİRE TESTERE MAKİNELERİ	FR20C 001H	2.525,00

TAŞINABİLİR MAKİNELER İÇİN TESTERELER

freud

Makiner: Taşınabilir makineler

D mm	B mm	b mm	d mm	Z	a°	NL	MAKİNE/AÇIKLAMA	ÜRÜN KODU	FİYAT
160	1.7	1.3	20	16	16	15°	SUNTA KESME MAKİNASI	LCL5M 02023	1.326,00
180	1.7	1.3	30	20	16	15°	SUNTA KESME MAKİNASI	LCL5M 02024	1.355,00
184	1.7	1.3	30	40	20/16	15°	SUNTA KESME MAKİNASI	LCL5M 02040	1.754,00
190	1.7	1.3	30	30	20	15°	SUNTA KESME MAKİNASI	LCL5M 02039	1.696,00
210	1.7	1.3	30	32	25/20	15°	SUNTA KESME MAKİNASI	LCL5M 02026	1.783,00
235	1.7	1.3	30	32	25	15°	SUNTA KESME MAKİNASI	LCL5M 02042	2.000,00

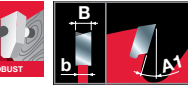
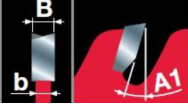



ALÜMİNYUM TESTERELERİ

Makineler:

Parçanın manuel ya da mekanik olarak bağlandığı gönye testereler

Malzeme:

Alüminyum ve demir olmayan metaller, PVC enjeksiyon profilleri

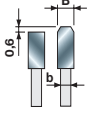

D mm	B mm	b mm	d mm	Z	a°	NL	MAKİNE/AÇIKLAMA	ÜRÜN KODU	FİYAT
200	2.8	2.2	30	64	5°		GÖNYELEME-OTM PROFİL	LU5B 0100	3.704,00
250	2.8	2.2	30	80	5°	FT02	GÖNYELEME-OTM PROFİL	LU5B 0201	4.007,00
300	3.0	2.5	30	96	5°	FT02	GÖNYELEME-OTM PROFİL	LU5B 0801	4.427,00
350	3.5	3.0	30	108	-6°	FT02	GÖNYELEME-OTM PROFİL	LU5D 1700	6.838,00
400	3.5	3.0	30	96	-6°	2/11/70	GÖNYELEME-OTM PROFİL	LU5C 1800	8.215,00
400	3.5	3.0	30	120	-6°		GÖNYELEME-OTM PROFİL	LU5D 2300	8.496,00
400	3.5	3.0	32	120	-6°	2/11/63	GÖNYELEME-OTM PROFİL	LU5D 2400	8.496,00
420	4.0	3.2	30	96	-6°	2/11/70	GÖNYELEME-OTM PROFİL	LU5C 2200	10.438,00
420	4.0	3.2	30	120	-6°	2/11/70	GÖNYELEME-OTM PROFİL	LU5D 2700	11.573,00
450	4.0	3.2	30	108	-6°		GÖNYELEME-OTM PROFİL	LU5C 2400	12.027,00
450	4.0	3.2	32	108	-6°	2/11/63	GÖNYELEME-OTM PROFİL	LU5C 2500	12.027,00
450	4.0	3.0	32	128	5°	2/11/63	GÖNYELEME-OTM PROFİL	LU5B 2800	12.027,00
450	4.0	3.0	30	128	-6°	2/11/63	GÖNYELEME-OTM PROFİL	LU5D 2900	12.027,00
500	4.0	3.2	30	120	-6°		GÖNYELEME-OTM PROFİL	LU5C 2800	13.091,00
500	4.0	3.2	32	120	-6°	2/11/63	GÖNYELEME-OTM PROFİL	LU5C 2900	13.091,00
500	4.0	3.2	32	140	5°	2/11/63	GÖNYELEME-OTM PROFİL	LU5B 3200	16.694,00
550	4.2	3.5	30	120	10°	2/10.5/70	GÖNYELEME-OTM PROFİL	LU5A 3100	17.328,00
550	4.2	3.5	30	132	10°	2/10.5/70	GÖNYELEME-OTM PROFİL	LU5A 2900	17.328,00

ALÜMİNYUM TESTERELERİ LU5F ÖZEL SERİ

İçlerindeki plastik profiller ile birlikte kapılar ve pencereler için 4,5 mm'ye kadar ince duvarlı alüminyum profilleri kesmek için testere bıçakları

Makineler:

Tek ve çift başlı makineler

Özellikler:

PİRAMİT dış tasarımı, kesme kenarındaki aşınmayı belirgin biçimde azaltan bir geometri konseptine sahiptir. Süper cilalı kesme kenarları alüminyum talaşların yüzeye yapışmasını daha da azaltır. Siyah Exrim kaplama alüminyum talaşları kanallardan hemen boşaltır. Talaşların çelik gövdeye kaynaklanmasını ve yüzeyin matlaşmasını engeller.

Malzeme:

Alüminyum ve demir olmayan metaller, PVC enjeksiyon profilleri

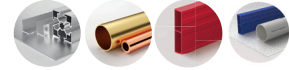
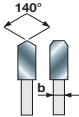

D mm	B mm	b mm	d mm	Z	a°	NL	MAKİNE/AÇIKLAMA	ÜRÜN KODU	FİYAT
600	4.7	4.0	30	144	7°	2/11/63, 2/11/70	HASSAS KESİM	LU5F 60001	27.978,00
600	4.7	4.0	32	144	7°	2/11/63, 2/11/70	HASSAS KESİM	LU5F 60002	27.978,00

DEMİR TESTERELERİ

Çekilmiş ürünleri, boruları ve demir çubukları kesmek için

Makineler:

Düşük güçlü kuru kesmede gönye testereler (yağ olmadan)

Özellikler:

Çift-trapez diş

Malzeme:

Demir içeren metaller, yumuşak çelik, bakır vb. için

UYARI: Yukarıda bahsedilen testereler aşağıdaki malzemeleri kesmek için uygun değildir:

- Demirli olmayan metaller (Alüminyum)

- Ağaç, cam, yığın vb.

Kesilecek olan iş parçalarının doğru bağlandığına emin olun.

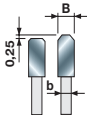

D mm	B mm	b mm	d mm	Z	a°	MAKİNE/AÇIKLAMA	ÜRÜN KODU	FİYAT
305	2.6	2.2	25.4	60	0°	METAL GÖNYE TESTERELERİ	LU6A 1100	6.979,00
305	2.6	2.2	25.4	80	0°	METAL GÖNYE TESTERELERİ	LU6A 1200	7.611,00
355	2.6	2.2	25.4	72	0°	METAL GÖNYE TESTERELERİ	LU6A 1500	7.611,00
355	2.6	2.2	25.4	90	0°	METAL GÖNYE TESTERELERİ	LU6A 1600	9.255,00

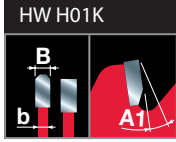
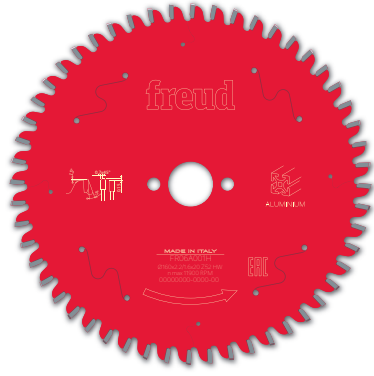

EL TİPİ DAİRE TESTERE MAKİNELERİ İÇİN ALÜMİNYUM KESİM TESTERELERİ

freud

Makineler: Gönye kesme makineleri için

Malzeme: Alüminyum, plastik, bakır ve piringç

Özellikler: -5° kesim açısına sahip düz-trapez diş



D mm	B mm	b mm	d mm	Z	a°	MAKİNA/AÇIKLAMA	ÜRÜN KODU	FİYAT
160	2.2	1.6	20	52	-5°	EL TİPİ DAİRE TESTERE MAKİNELERİ	FR06A 001H	2.827,00
165	2.5	1.6	20	52	-5°	EL TİPİ DAİRE TESTERE MAKİNELERİ	FR07A 001H	3.141,00
180	2.5	1.6	30	56	-5°	EL TİPİ DAİRE TESTERE MAKİNELERİ	FR09A 001H	3.178,00
190	2.5	1.6	30	56	-5°	EL TİPİ DAİRE TESTERE MAKİNELERİ	FR13A 002H	3.178,00
210	2.3	1.8	30	72	-5°	EL TİPİ DAİRE TESTERE MAKİNELERİ	FR15A 001H	3.905,00
230	2.8	1.8	30	64	-5°	EL TİPİ DAİRE TESTERE MAKİNELERİ	FR19A 001H	4.071,00
235	2.5	1.8	30	80	-5°	EL TİPİ DAİRE TESTERE MAKİNELERİ	FR20A 001H	4.389,00

GÖNYE KESME MAKİNELERİ İÇİN ALÜMİNYUM KESİM TESTERELERİ

freud

Makineler: Gönye kesme makineleri için

Malzeme: Alüminyum, plastik, bakır ve piringç

Özellikler: -5° kesim açısına sahip düz-trapez diş



D mm	B mm	b mm	d mm	Z	a°	MAKİNA/AÇIKLAMA	ÜRÜN KODU	FİYAT
210	2.5	1.8	30	54	-5°	GÖNYE KESME MAKİNELERİ	FR15A 001M	3.309,00
216	2.5	1.8	30	64	-5°	GÖNYE KESME MAKİNELERİ	FR16A 001M	3.600,00
260	2.3	1.8	30	80	-5°	GÖNYE KESME MAKİNELERİ	FR26A 001M	4.228,00

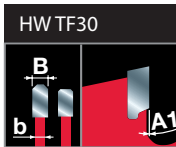

EL TİPİ DAİRE TESTERE MAKİNELERİ İÇİN ÇOKLU MATERYAL KESİM TESTERELERİ

freud

Makineler: Portatif el tipi daire testere makineleri için

Malzeme:

Sunta, mdf, kontrplak alüminyum, plastik, bakır ve piringç, ince demir profil

Özellikler: 0° kesim açısına sahip trapez-trapez diş



D mm	B mm	b mm	d mm	Z	a°	MAKİNA/AÇIKLAMA	ÜRÜN KODU	FİYAT
160	2.0	1.6	20	30	0°	EL TİPİ DAİRE TESTERE MAKİNELERİ	FR06M 001H	3.157,00
184	2.0	1.6	30	36	0°	EL TİPİ DAİRE TESTERE MAKİNELERİ	FR11M 001H	3.849,00
190	2.0	1.6	30	38	0°	EL TİPİ DAİRE TESTERE MAKİNELERİ	FR13M 001H	3.927,00
230	2.4	2.0	30	44	0°	EL TİPİ DAİRE TESTERE MAKİNELERİ	FR19M 001H	4.908,00

GÖNYE KESME MAKİNELERİ İÇİN ÇOKLU MATERYAL KESİM TESTERELERİ

freud

Makineler: Gönye kesme makineleri için

Malzeme:

Sunta, mdf, kontrplak alüminyum, plastik, bakır ve piringç, ince demir profil

Özellikler: 0° kesim açısına sahip trapez-trapez diş



D mm	B mm	b mm	d mm	Z	a°	MAKİNA/AÇIKLAMA	ÜRÜN KODU	FİYAT
210	2.0	1.6	30	40	0°	GÖNYE KESME MAKİNELERİ	FR15M 001M	4.213,00
216	2.0	1.6	30	40	0°	GÖNYE KESME MAKİNELERİ	FR16M 001M	4.273,00
250	2.4	2.0	30	48	0°	GÖNYE KESME MAKİNELERİ	FR23M 001M	5.474,00
300	2.6	2.0	30	80	0°	GÖNYE KESME MAKİNELERİ	FR28M 001M	7.582,00



MADE BY freud
MADE IN ITALY

EL TİPİ DAİRE TESTERE MAKİNELERİ İÇİN SANDWICH PANEL KESİM TESTERELERİ

freud

Makineler: Portatif el tipi daire testere makineleri için
Özellikler: 0° kesim açısına sahip trapez-trapez diş

Malzeme: Sandwich panel



D mm	B mm	b mm	d mm	Z	a°	MAKİNA/AÇIKLAMA	ÜRÜN KODU	FİYAT
160	2.0	1.6	20	30	0°	EL TİPİ DAİRE TESTERE MAKİNELERİ	FR06X 001H	2.430,00
165	2.0	1.6	20	30	0°	EL TİPİ DAİRE TESTERE MAKİNELERİ	FR07X 001H	2.579,00
190	2.0	1.6	30	36	0°	EL TİPİ DAİRE TESTERE MAKİNELERİ	FR13X 001H	3.141,00
210	2.4	2.0	30	36	0°	EL TİPİ DAİRE TESTERE MAKİNELERİ	FR15X 001H	3.346,00
230	2.2	1.8	30	48	0°	EL TİPİ DAİRE TESTERE MAKİNELERİ	FR19X 001H	3.734,00
235	2.2	1.8	30	50	0°	EL TİPİ DAİRE TESTERE MAKİNELERİ	FR20X 001H	4.044,00
270	2.4	2.0	30	60	0°	EL TİPİ DAİRE TESTERE MAKİNELERİ	FR27X 001H	5.882,00
350	2.9	2.5	30	60	0°	EL TİPİ DAİRE TESTERE MAKİNELERİ	FR32X 001H	7.432,00
355	2.6	2.2	30	80	0°	EL TİPİ DAİRE TESTERE MAKİNELERİ	FR33X 001H	8.037,00

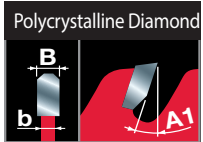

EL TİPİ DAİRE TESTERE MAKİNELERİ İÇİN BETOPAN KESİM TESTERELERİ

freud

Makineler: Portatif el tipi daire testere makineleri için
Özellikler: 10° kesim açısına sahip PCD (Polycrystalline Diamond) trapez diş

Malzeme: Fibre cement (betopan), alçıpan



D mm	B mm	b mm	d mm	Z	a°	MAKİNA/AÇIKLAMA	ÜRÜN KODU	FİYAT
184	2.2	1.6	30	4	10°	EL TİPİ DAİRE TESTERE MAKİNELERİ	FR11F 001H	5.670,00
235	2.2	1.6	30	6	10°	EL TİPİ DAİRE TESTERE MAKİNELERİ	FR20F 001H	7.911,00

GÖNYE KESME MAKİNELERİ İÇİN BETOPAN KESİM TESTERELERİ

freud

Makineler: Gönye kesme makineleri için
Özellikler: 10° kesim açısına sahip PCD (Polycrystalline Diamond) trapez diş

Malzeme: Fibre cement (betopan), alçıpan



D mm	B mm	b mm	d mm	Z	a°	MAKİNA/AÇIKLAMA	ÜRÜN KODU	FİYAT
254	2.4	1.8	30	6	10°	GÖNYE KESME MAKİNELERİ	FR24F 001M	8.769,00
305	2.4	1.8	30	8	10°	GÖNYE KESME MAKİNELERİ	FR29F 001M	10.613,00

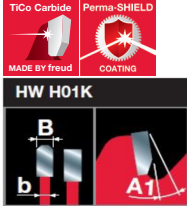

EL TİPİ DAİRE TESTERE MAKİNELERİ İÇİN KOMPAKT LAMİNAT KESİM TESTERELERİ

freud

Makineler: Portatif el tipi daire testere makineleri için
Özellikler: 0° kesim açısına sahip düz-trapez diş

Malzeme: Kompakt laminat, corian



D mm	B mm	b mm	d mm	Z	a°	MAKİNE/AÇIKLAMA	ÜRÜN KODU	FİYAT
160	2.2	1.6	20	48	0°	EL TİPİ DAİRE TESTERE MAKİNELERİ	FR06H 001H	2.952,00
165	2.6	1.6	20	48	0°	EL TİPİ DAİRE TESTERE MAKİNELERİ	FR07H 001H	3.064,00
190	2.6	1.6	30	56	0°	EL TİPİ DAİRE TESTERE MAKİNELERİ	FR13H 002H	3.735,00
210	2.8	1.8	30	60	0°	EL TİPİ DAİRE TESTERE MAKİNELERİ	FR15H 001H	4.052,00
235	2.8	1.8	30	64	0°	EL TİPİ DAİRE TESTERE MAKİNELERİ	FR20H 001H	4.483,00

GÖNYE KESME MAKİNELERİ İÇİN KOMPAKT LAMİNAT KESİM TESTERELERİ

freud

Makineler: Gönye kesme makineleri için
Özellikler: 0° kesim açısına sahip düz-trapez diş

Malzeme: Kompakt laminat, corian



D mm	B mm	b mm	d mm	Z	a°	MAKİNE/AÇIKLAMA	ÜRÜN KODU	FİYAT
250	2.8	1.8	30	80	-3°	GÖNYE KESME MAKİNELERİ	FR23H 001M	5.305,00
305	3.2	2.2	30	96	-3°	GÖNYE KESME MAKİNELERİ	FR29H 001M	6.425,00



DÜZ KARBÜR VE HW FREZE BIÇAKLARI

Makineler:

El tipi yönlendiriciler, masa yönlendiriciler ve CNC

Malzeme:

Yumuşak ve sert ağaç, kontrplak ve ahşap

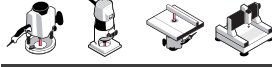

D mm	h mm	H mm	A mm	Z	MAKSİMUM DEVİR	ÜRÜN KODU	FİYAT
3	12	50	6	2	24.000	R006M03006	1.289,00
4	15.8	50.7	6	2	24.000	04-10106P	1.061,00
5	16	51	6	2	24.000	R006M07406	1.416,00
6	25	63	6	2	24.000	R006M10206	1.516,00

Tip A Komple Karbürler

D mm	h mm	H mm	A mm	Z	MAKSİMUM DEVİR	ÜRÜN KODU	FİYAT
3	8	58	12	2	24.000	12-09612P	1.478,00
4	10	58	12	2	24.000	12-09712P	1.571,00
5	12.7	57	12	2	24.000	12-09812P	1.574,00
6	19	64	12	2	24.000	12-09912P	1.449,00

Tip B Gömmeli Karbürler

D mm	h mm	H mm	A mm	Z	MAKSİMUM DEVİR	ÜRÜN KODU	FİYAT
8	19.1	52	6	2	24.000	04-11506P	961,00
10	25.4	62.4	6	2	24.000	MM-01006P	1.061,00
12	19	55.5	6	2	24.000	04-13506P	1.012,00
14	19	56	6	2	24.000	04-14306P	1.064,00
16	19	51	6	2	24.000	04-14906P	1.102,00
20	19	56	6	2	24.000	04-15506P	1.144,00
7	18	67	12	2	24.000	12-10312P	1.102,00
8	31.8	76	12	2	24.000	12-10712P	1.239,00
9	31.8	76	12	2	24.000	12-11012P	1.199,00
10	31.8	76	12	2	24.000	12-11212P	1.213,00
12	38.1	80	12	2	24.000	12-12212P	1.213,00
12	50.5	98	12	2	24.000	12-12812P	1.302,00
14	31.8	73	12	2	24.000	12-13412P	1.261,00
15	31.8	69.8	12	2	24.000	12-13512P	1.315,00
16	38.1	76.1	12	2	24.000	12-14012P	1.364,00
18	38.1	80	12	2	24.000	12-14312P	1.447,00
19	25.4	63.4	12	2	24.000	12-15212P	1.345,00
20	38.1	80	12	2	24.000	12-15912P	1.557,00
22	38.1	80	12	2	24.000	12-16912P	1.644,00

Tip C HW Frezeler

ÜSTTEN RULMANLI FREZE BIÇAĞI

Makineler:

El tipi yönlendiriciler ve masa yönlendiriciler

Malzeme:

Yumuşak ve sert ağaç, kontrplak ve ahşap

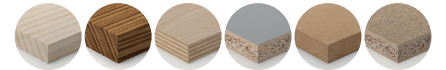

D mm	h mm	H mm	A mm	Z	ÜRÜN KODU	FİYAT
13	20	60	6	2	50-10206P	1.499,00

RULMANLI TEMİZLEME FREZE BIÇAKLARI

Laminat tezgahlarda hassas düzeltme çalışmaları yapmak, desenleri takip etmek ve karmaşık şekiller oluşturmak veya çoğaltmak için bu uçları kullanın.

Makineler:

El tipi yönlendiriciler ve masa yönlendiriciler



Malzeme:

Yumuşak ve sert ağaç, kontrplak ve ahşap paneller



D mm	h mm	H mm	A mm	Z	MAKSİMUM DEVİR	ÜRÜN KODU	FİYAT
9.53	25.8	72.4	6	2		42-10006P	1.077,00
12.7	25.7	72.9	6	2		42-10406P	1.071,00
9.53	25.8	72.4	8	2		42-10008P	1.106,00
12.7	25.7	72.9	8	2		42-10408P	1.126,00
12.7	25.4	82.5	12	2		42-11012P	1.264,00
12.7	38.5	94.1	12	2		42-11412P	1.386,00
12.7	50.8	106.8	12	2		42-11612P	1.544,00

RULMANLI / RULMANSIZ PAH FREZE BIÇAKLARI

Kenarları yumuşatan pah kırma uçları, herhangi bir iş parçasının kenarında düzgün bir pah oluşturur.

Makineler:

El tipi yönlendiriciler, masa yönlendiriciler ve CNC makineleri. **Rulmanlı uçların CNC makinelerde kullanılması tavsiye edilmez.**

Malzeme:

Yumuşak ve sert ağaç, kontrplak ve ahşap paneller

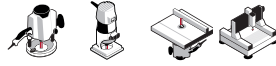

D mm	h mm	H mm	A mm	Z	C mm	a°	MAKSİMUM DEVİR	ÜRÜN KODU	FİYAT
25.4	25.1	67.25	6	2	12.7	15°	24.000	40-09806P	1.871,00
30.1	22.5	64.7	6	2	12.7	22.5°	18.000	40-10106P	1.922,00
31	9.5	52.3	6	2	12.7	45°	18.000	40-10506P	1.416,00
24	14	46	6	2		15°	24.000	40-90006P	1.619,00
24	12	44	6	2		30°	24.000	40-90206P	1.668,00
25	8	40.3	6	2		45°	24.000	40-90406P	1.567,00
25.4	25.1	73.25	12	2	12.7	15°	24.000	40-09812P	2.070,00
30.1	22.5	70.7	12	2	12.7	22.5°	18.000	40-10112P	2.070,00
44	18.5	67	12	2	12.7	45°	16.000	40-11412P	2.022,00

RULMANLI LAMBA YERİ AÇMA FREZE BIÇAKLARI

Güçlü bindirmeli bağlantılar yapmak, dolapların arka panellerine girmek için girintiler kesmek veya gömme kalıpta ilginç bir ayrıntı oluşturmak için kullanın.

Makineler:

El tipi yönlendiriciler ve masa yönlendiriciler

Malzeme:

Yumuşak ve sert ağaç, kontrplak ve ahşap paneller

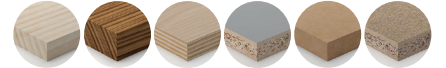

D mm	h mm	H mm	A mm	Z	C mm	P mm	MAKSİMUM DEVİR	ÜRÜN KODU	FİYAT
31.75	13.2	55.7	6	2	12.7	9.52	18.000	32-10006P	1.303,00
34.92	12.7	54.4	6	2	12.7	11.1	16.000	32-50006P	1.354,00
31.75	13.2	61.7	12	2	12.7	9.52	18.000	32-10212P	1.587,00
34.92	12.7	60.7	12	2	12.7	11.1	16.000	32-52012P	1.647,00

RULMANLI BALIK SIRTI FREZE BIÇAKLARI

Herhangi bir iş parçasının keskin kenarlarını yumuşatır.

Makineler:

El tipi yönlendiriciler ve masa yönlendiriciler

Malzeme:

Yumuşak ve sert ağaç, kontrplak ve ahşap



D mm	h mm	H mm	A mm	Z	C mm	R mm	MAKSİMUM DEVİR	ÜRÜN KODU	FİYAT
16.7	12.7	54.9	6	2	12.7	2	24.000	34-10106P	1.229,00
19.05	12.7	55.2	6	2	12.7	3.18	24.000	34-10406P	1.400,00
22.22	12.7	54.9	6	2	12.7	4.8	24.000	34-10806P	1.154,00
25.4	12.7	55.2	6	2	12.7	6.35	24.000	34-11006P	1.248,00
28.58	12.7	55.2	6	2	12.7	8	18.000	34-11206P	1.334,00
31.75	18	59.7	6	2	12.7	9.53	18.000	34-11406P	1.400,00
38.1	19.1	61.25	6	2	12.7	12.7	16.000	34-11606P	1.581,00
16.7	12.7	54.9	8	2	12.7	2	24.000	34-10108P	1.194,00
18.7	12.7	54.9	8	2	12.7	3	24.000	34-10308P	1.302,00
22.22	13.2	54.9	8	2	12.7	4.75	24.000	34-10808P	1.174,00
25.4	12.7	55.2	8	2	12.7	6.35	24.000	34-11008P	1.299,00
28.58	12.7	55.2	8	2	12.7	7.94	18.000	34-11208P	1.357,00
31.75	18	59.7	8	2	12.7	9.5	18.000	34-11408P	1.209,00
38.1	19.1	61.25	8	2	12.7	12.7	16.000	34-11608P	1.636,00
44.44	22.2	64.72	8	2	12.7	15.8	16.000	34-12708P	1.944,00
25.4	12.7	61.2	12	2	12.7	6.35	24.000	34-12012P	1.603,00
31.75	18	65.7	12	2	12.7	9.53	18.000	34-12412P	1.786,00
38.1	19.05	67.25	12	2	12.7	12.7	16.000	34-12612P	1.994,00
44.44	22.22	70.72	12	2	12.7	15.8	16.000	34-12712P	2.351,00
50.8	25.4	73.9	12	2	12.7	19	16.000	34-12812P	2.419,00
57.15	31.4	79.85	12	2	12.7	22.2	16.000	34-13012P	3.952,00
63.5	31.3	79.75	12	2	12.7	25.4	12.000	34-13212P	3.952,00
69.85	34.9	83.3	12	2	12.7	28.6	12.000	34-13412P	4.329,00
76.2	38.1	86.6	12	2	12.7	31.8	12.000	34-13612P	4.971,00

RULMANLI TERS BALIK SIRTI FREZE BIÇAKLARI

Geleneksel mobilyalar için dekoratif içbükey kenar.

Makineler:

El tipi yönlendiriciler ve masa yönlendiriciler

Malzeme:

Yumuşak ve sert ağaç, kontrplak ve ahşap paneller



D mm	h mm	H mm	A mm	Z	C mm	R mm	MAKSİMUM DEVİR	ÜRÜN KODU	FİYAT
25.4	12.7	54.7	6	2	9.53	8	24.000	30-10306P	1.489,00
31.75	12.7	55.2	6	2	12.7	9.53	18.000	30-10406P	1.489,00
38.1	16.4	58.9	6	2	12.7	12.7	16.000	30-10606P	1.561,00
19.05	14	62.4	12	2	9.53	4.75	24.000	30-10012P	1.567,00
22.23	12.7	60.7	12	2	9.53	6.35	24.000	30-11012P	1.451,00
25.4	12.7	60.7	12	2	9.53	8	24.000	30-11112P	1.728,00
31.75	12.7	61.2	12	2	12.7	9.5	18.000	30-11212P	1.778,00

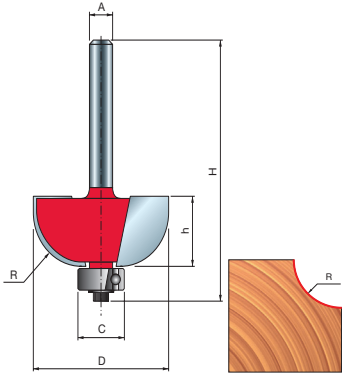

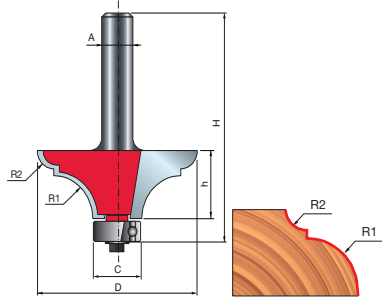

RULMANLI TAÇ MOTİF FREZE BİÇAĞI

Herhangi bir iş parçası üzerinde dekoratif kenar detayı.

Makineler:

El tipi yönlendiriciler ve masa yönlendiriciler

Malzeme:

Yumuşak ve sert ağaç, kontrplak ve ahşap paneller



D	h	H	A	Z	C	R1/R2	MAKSİMUM DEVİR	ÜRÜN KODU	FİYAT
41.3	15.9	64.4	12	2	12.7	10/4.3	16.000	99-01112P	2.057,00

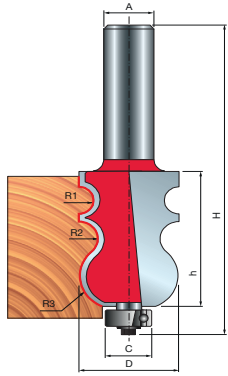

RULMANLI ÇOKLU MOTİF FREZE BİÇAĞI

Yükseklik ve korkuluk ayarlarını değiştirerek ve çoklu geçişler yaparak sonsuz sayıda profil tasarımı üretin.

Makineler:

Masa tipi yönlendiriciler

Malzeme:

Yumuşak ve sert ağaç, kontrplak ve ahşap paneller

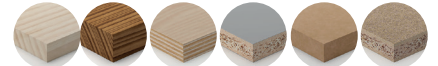

D	h	H	A	Z	C	R1/R2/R3	MAKSİMUM DEVİR	ÜRÜN KODU	FİYAT
23.8	35	83.5	12	2	12.7	3.5/4.5/8.5	24.000	99-01312P	2.561,00

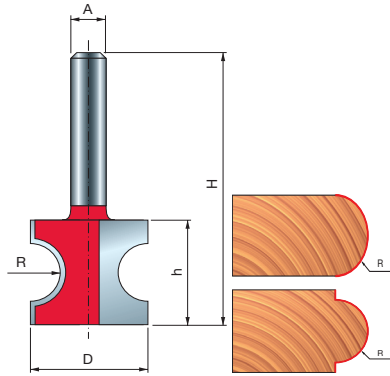

YARIMAY FREZE BİÇAKLARI

Herhangi bir iş parçasında tamamen yuvarlatılmış yarım daire biçimli bitiş oluşturur.

Makineler:

El tipi yönlendiriciler, masa yönlendiriciler ve CNC makineleri

Malzeme:

Yumuşak ve sert ağaç, kontrplak ve ahşap paneller

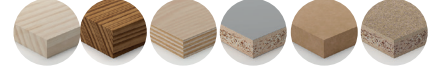
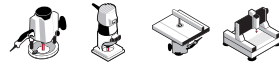

D	h	H	A	Z	R	MAKSİMUM DEVİR	ÜRÜN KODU	FİYAT
19	12.4	53.4	12	2	3.2	24.000	82-11012P	1.373,00
22.22	19.5	60.5	12	2	4.76	24.000	82-11212P	1.749,00
25.4	22.9	64.9	12	2	6.35	24.000	82-11412P	1.844,00
37	29.05	71.05	12	2	9.5	16.000	82-11612P	2.109,00
45.9	35.4	73.4	12	2	12.7	16.000	82-11812P	3.278,00

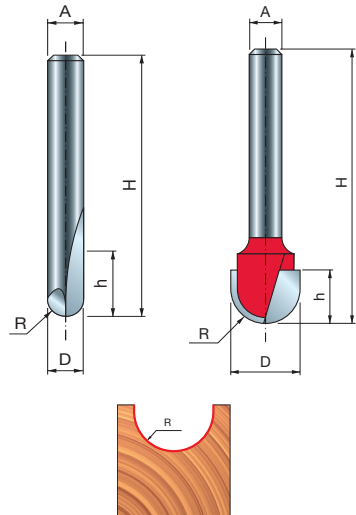

KÜRE FREZE BİÇAKLARI

Yarım daire biçimli oyulmuş oluklar yapar.

Makineler:

El tipi yönlendiriciler, masa yönlendiriciler ve CNC makineleri. **Rulmanlı uçların CNC makinelerde kullanılması tavsiye edilmez.**

Malzeme:

Yumuşak ve sert ağaç, kontrplak ve ahşap paneller

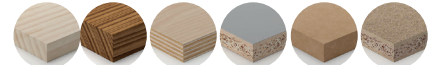
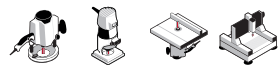

D	h	H	A	Z	R	MAKSİMUM DEVİR	ÜRÜN KODU	FİYAT
6	12.7	50.8	6	2	3	24.000	*18-10406P	1.365,00
6	9.5	57	12	2	3	24.000	*18-11412P	1.770,00
9.52	9	46	6	2	4.8	24.000	18-10606P	868,00
12	9	46	6	2	6	24.000	18-10806P	906,00
15.88	11	50.8	6	2	8	24.000	18-11006P	961,00
12.7	31.7	71.5	12	2	6.35	24.000	18-11612P	1.409,00
19.05	31.7	73	12	2	9.5	24.000	18-12212P	1.576,00
25.4	31.7	73	12	2	12.7	24.000	18-12612P	2.109,00

* Karbür

RULMANLI SOFT MOTİF FREZE BIÇAKLARI

Herhangi bir iş parçası üzerinde dekoratif kenar detayı.

Makinelere:

El tipi yönlendiriciler ve masa yönlendiriciler

Malzeme:

Yumuşak ve sert ağaç, kontrplak ve ahşap paneller

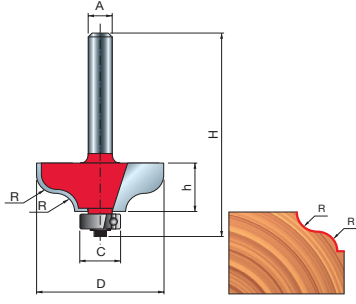

D mm	h mm	H mm	A mm	Z	C mm	R mm	MAKSİMUM DEVİR	ÜRÜN KODU	FİYAT
31.75	12.2	53.9	6	2	9.53	4.8	18.000	38-20206P	1.512,00
38.1	16.2	57.4	6	2	9.53	6.35	16.000	38-20406P	1.886,00
31.75	12.2	53.9	8	2	9.53	4.8	18.000	38-20208P	1.574,00
38.1	16.2	57.4	8	2	9.53	6.35	16.000	38-20408P	1.964,00
31.75	12.2	59.9	12	2	9.53	4.8	18.000	38-21212P	1.891,00
38.1	16.2	63.4	12	2	9.53	6.35	16.000	38-21412P	2.141,00

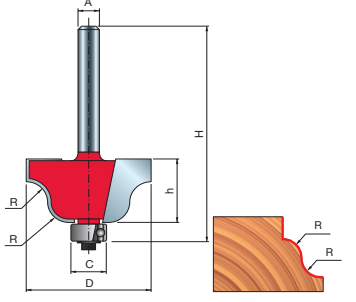

D mm	h mm	H mm	A mm	Z	C mm	R mm	MAKSİMUM DEVİR	ÜRÜN KODU	FİYAT
27	13.3	61.31	12	2	9.53	4	18.000	38-10412P	1.623,00
35	18.5	66.5	12	2	9.53	6.35	16.000	38-10612P	1.839,00

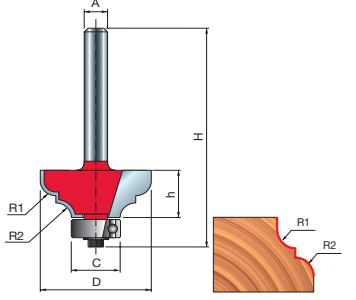

D mm	h mm	H mm	A mm	Z	C mm	R1/R2 mm	MAKSİMUM DEVİR	ÜRÜN KODU	FİYAT
28.58	12.7	54.9	6	2	12.7	4/4	18.000	38-60206P	1.471,00
28.58	12.7	54.9	8	2	12.7	4/4	18.000	38-60208P	1.534,00
28.58	12.7	61.2	12	2	12.7	4/4	18.000	38-61212P	1.789,00
34.92	17.5	65.7	12	2	12.7	6.35/4.76	16.000	38-61412P	2.252,00

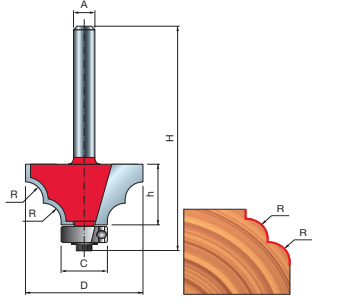

D mm	h mm	H mm	A mm	Z	C mm	R mm	MAKSİMUM DEVİR	ÜRÜN KODU	FİYAT
32.7	15	57.2	6	2	12.7	5	16.000	38-90006P	1.839,00

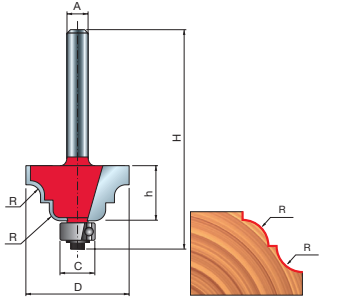

D mm	h mm	H mm	A mm	Z	C mm	R mm	MAKSİMUM DEVİR	ÜRÜN KODU	FİYAT
29.38	13.5	61.2	12	2	9.53	3.97	18.000	38-31212P	1.941,00
38.92	18.3	66	12	2	9.53	6.35	16.000	38-31412P	2.175,00

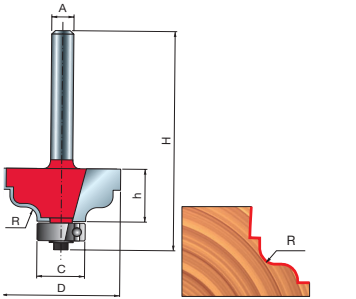

D mm	h mm	H mm	A mm	Z	C mm	R mm	MAKSİMUM DEVİR	ÜRÜN KODU	FİYAT
34.92	14.3	62.8	12	2	12.7	4.8	16.000	99-00512P	2.333,00

KIRLANGIÇ FREZE BIÇAKLARI

Kırlangıç bağlantılar, çekmeceler, kutular ve açıkta kalan mobilya bağlantıları için güçlü, çekici bağlantılar için geleneksel seçimdir.

Makineler:

El tipi yönlendiriciler, masa yönlendiriciler ve CNC makineleri

Malzeme:

Yumuşak ve sert ağaç, kontrplak ve ahşap paneller

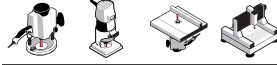

D mm	h mm	H mm	A mm	Z	a°	MAKSİMUM DEVİR	ÜRÜN KODU	FİYAT
12.7	12.7	59.7	12	2	14°	24.000	22-11212P	1.077,00
19.05	22.2	66.7	12	2	7°	24.000	22-11412P	1.329,00

V KANAL FREZE BIÇAKLARI

V şeklindeki oluklar, tabela yapımı, gravür ve dekoratif detaylar için uygundur.

Makineler:

El tipi yönlendiriciler, masa yönlendiriciler ve CNC makineleri

Malzeme:

Yumuşak ve sert ağaç, kontrplak ve ahşap paneller

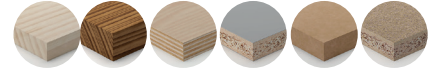
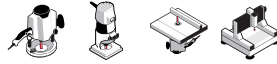

D mm	h mm	H mm	A mm	Z	a°	MAKSİMUM DEVİR	ÜRÜN KODU	FİYAT
6	6	38.1	6	1	90°	24.000	*20-10006P	1.003,00
12.7	10	44.4	6	2	90°	24.000	20-10406P	922,00
19.05	12.5	57.2	12	2	90°	24.000	20-10812P	1.236,00

* Karbür

PANEL BOŞALTMA FREZE BIÇAĞI

Panel ve diğer uygulamalarda açıklıkları kesmek ve kırmak için hızlı ve verimli bir çözümdür

Makineler:

El tipi yönlendiriciler

Malzeme:

Yumuşak ve sert ağaç, kontrplak ve ahşap paneller

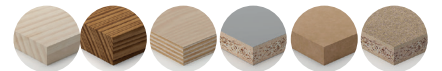

D mm	h mm	H mm	A mm	Z	MAKSİMUM DEVİR	ÜRÜN KODU	FİYAT
12.7	31.75	96.2	12	2	24.000	28-10412P	1.323,00

45° EKLEME FREZE BIÇAKLARI

Son derece güçlü birbirine kenetlenen bağlantılar oluşturur.

Makineler:

Masa tipi yönlendiriciler ve CNC makinesi

Malzeme:

Yumuşak ve sert ağaç, kontrplak, ahşap kompozitler ve tüm katı yüzey malzemeleri

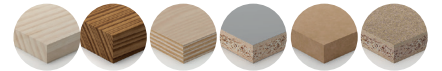
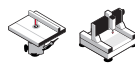

D mm	h mm	H mm	A mm	a°	Z	MAKSİMUM DEVİR	ÜRÜN KODU	FİYAT
55	23	61	12	45°	2	16.000	99-03512P	3.423,00
70	29.5	67.5	12	45°	2	12.000	99-03412P	4.797,00

FINGER JOINT FREZE BIÇAĞI

Tamamen düz bir yüzey oluşturun ve daha güçlü bir bağlantı için yapıştırma alanını genişletin.

Makineler:
Masa yönlendiriciler ve CNC makineleri

Malzeme:
Yumuşak ve sert ağaç, kontrplak ve ahşap paneller

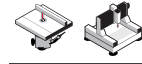
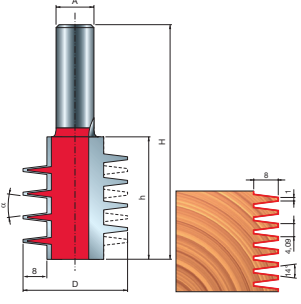

D mm	h mm	H mm	A mm	Z	a°	MAKSİMUM DEVİR	ÜRÜN KODU	FİYAT
35	41.5	79.5	12	2	14°	16.000	99-03712P	4.337,00

RULMANLI CORIAN FREZE BIÇAKLARI

Pürüzsüz, yuvarlak bir kenar oluşturmak için masif yüzeyli tezgahlar ile masif yüzeyli lavabolar arasındaki bağlantıyı kesmek için tasarlanmıştır.

Makineler:
El tipi yönlendiriciler ve masa yönlendiriciler

Malzeme: Yumuşak ve sert ağaç, kontrplak, ahşap kompozitler ve tüm katı yüzey malzemeleri

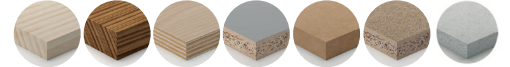
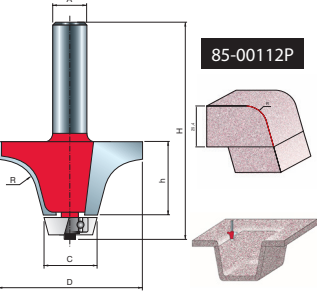

D mm	h mm	H mm	A mm	Z	C mm	R mm	MAKSİMUM DEVİR	ÜRÜN KODU	FİYAT
54	25.4	74.6	12	2	22.2	12.7	16.000	85-00112P	4.294,00
57.2	31.8	81	12	2	22.2	12.7	12.000	85-00312P	4.550,00

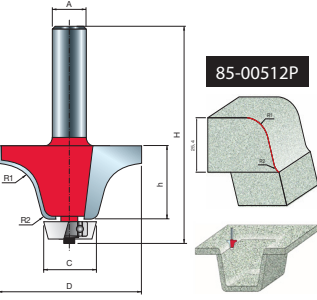

D mm	h mm	H mm	A mm	Z	C mm	a°	MAKSİMUM DEVİR	ÜRÜN KODU	FİYAT
54	25.4	74.6	12	2	19.2	12.7/6.35	16.000	85-00512P	3.882,00
57.2	31.8	80.9	12	2	19.2	12.7/6.35	12.000	85-00712P	4.442,00

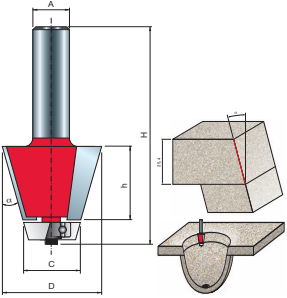

ALUMİNYUM PANEL KATLAMA İÇİN V KANAL FREZE BIÇAKLARI

Alüminyum panellerin kolay ve kırılmadan katlanması için V kanal açılması için tasarlanmıştır.

Makineler:
El tipi yönlendiriciler, masa yönlendiriciler ve CNC makineleri

Malzeme:
Alüminyum, Yumuşak ve sert ağaç, kontrplak ve ahşap paneller

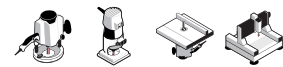
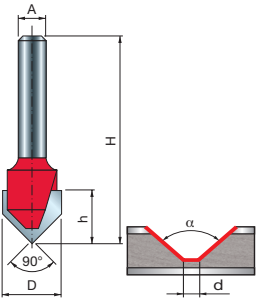

D mm	h1 mm	h2 mm	H mm	A mm	d mm	a°	Z	MAKSİMUM DEVİR	ÜRÜN KODU	FİYAT
16	12.5	6.8	50.8	6	2.5	90°	2	24.000	21-11206P	1.664,00
16	12.5	6.8	50.8	8	2.5	90°	2	24.000	21-11208P	1.719,00



YARIM DELİK MATKAP UÇLARI 57,5 MM

Kör delikler için merkez noktalı HW uçlu dübel matkapları.

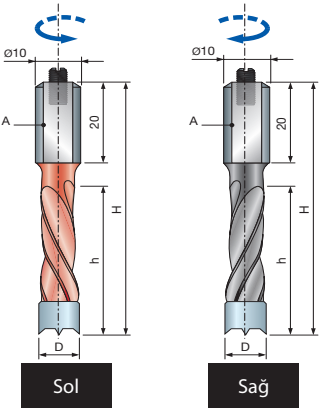
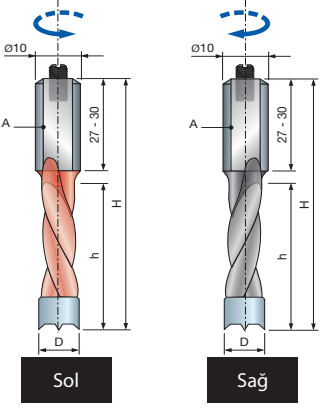
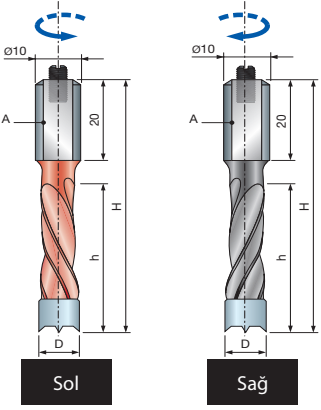
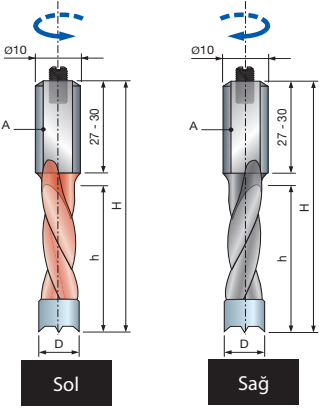
Makineler:
CNC, delme ve çoklu delme makineleri**Malzemeler:** Yumuşak ve sert ağaç, ahşap paneller ve MDF

D mm	h mm	H mm	A mm	Z	MAKİNE/AÇIKLAMA	SOL	SAĞ	FİYAT
4	27	57.5	10x27	2	ÇOKLU DELİK-CNC DELİK	PF06MS ZA3	PF06MD ZA3	747,00
5	27	57.5	10x27	2	ÇOKLU DELİK-CNC DELİK	PF06MS AA3	PF06MD AA3	596,00
6	27	57.5	10x27	2	ÇOKLU DELİK-CNC DELİK	PF06MS BA3	PF06MD BA3	699,00
8	27	57.5	10x27	2	ÇOKLU DELİK-CNC DELİK	PF06MS DA3	PF06MD DA3	654,00
9	27	57.5	10x27	2	ÇOKLU DELİK-CNC DELİK	PF06MS EA3	PF06MD EA3	876,00
10	27	57.5	10x27	2	ÇOKLU DELİK-CNC DELİK	PF06MS FA3	PF06MD FA3	855,00

YARIM DELİK MATKAP UÇLARI 57,5 MM (ÇİFT TALAŞ)

Makineler:
CNC, delme ve çoklu delme makineleri**Malzemeler:** Yumuşak ve sert ağaç, ahşap paneller ve MDF

D mm	h mm	H mm	A mm	Z	MAKİNE/AÇIKLAMA	SOL	SAĞ	FİYAT
4	27	57.5	10X20	2	ÇOKLU DELİK-CNC DELİK	PF07MS ZA3	PF07MD ZA3	747,00
5	30	57.5	10X20	2	ÇOKLU DELİK-CNC DELİK	PF07MS AA3	PF07MD AA3	596,00
8	30	57.5	10X20	2	ÇOKLU DELİK-CNC DELİK	PF07MS DA3	PF07MD DA3	654,00
10	30	57.5	10X20	2	ÇOKLU DELİK-CNC DELİK	PF07MS FA3	PF07MD FA3	855,00

YARIM DELİK MATKAP UÇLARI 70 MM

Makineler:
CNC, delme ve çoklu delme makineleri**Malzemeler:** Yumuşak ve sert ağaç, ahşap paneller ve MDF

D mm	h mm	H mm	A mm	Z	MAKİNE/AÇIKLAMA	SOL	SAĞ	FİYAT
3	22	70	10X33	2	ÇOKLU DELİK-CNC DELİK	*PF26MS VC3	*PF26MD VC3	1.003,00
4	27	70	10X30	2	ÇOKLU DELİK-CNC DELİK	*PF26MS ZC3	*PF26MD ZC3	1.034,00
5	35	70	10X30	2	ÇOKLU DELİK-CNC DELİK	PF06MS AC3	PF06MD AC3	674,00
6	35	70	10X30	2	ÇOKLU DELİK-CNC DELİK	PF06MS BC3	PF06MD BC3	758,00
7	35	70	10X30	2	ÇOKLU DELİK-CNC DELİK	PF06MS CC3	PF06MD CC3	795,00
8	35	70	10X30	2	ÇOKLU DELİK-CNC DELİK	PF06MS DC3	PF06MD DC3	674,00
9	35	70	10X30	2	ÇOKLU DELİK-CNC DELİK	PF06MS EC3	PF06MD EC3	855,00
10	35	70	10X30	2	ÇOKLU DELİK-CNC DELİK	PF06MS FC3	PF06MD FC3	855,00
12	35	70	10X30	2	ÇOKLU DELİK-CNC DELİK	PF06MS GC3	PF06MD GC3	944,00

* KARBÜR

YARIM DELİK MATKAP UÇLARI 70 MM (ÇİFT TALAŞ)

Makineler:
CNC, delme ve çoklu delme makineleri**Malzemeler:** Yumuşak ve sert ağaç, ahşap paneller ve MDF

D mm	h mm	H mm	A mm	Z	MAKİNE/AÇIKLAMA	SOL	SAĞ	FİYAT
5	43	70	10X20	2	ÇOKLU DELİK-CNC DELİK	PF07MS AC3	PF07MD AC3	674,00
8	43	70	10X20	2	ÇOKLU DELİK-CNC DELİK	PF07MS DC3	PF07MD DC3	674,00
10	43	70	10X20	2	ÇOKLU DELİK-CNC DELİK	PF07MS FC3	PF07MD FC3	855,00

TAM DELİK MATKAP UÇLARI 57,5 MM

Makineler:
CNC, delme ve çoklu delme makineleri

Malzemeler: Yumuşak ve sert ağaç, ahşap paneller ve MDF

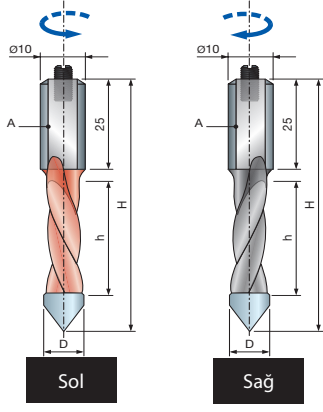

D mm	h mm	H mm	A mm	Z	MAKİNE/AÇIKLAMA	SOL	SAĞ	FİYAT
4	22	57.5	10x25	2	ÇOKLU DELİK-CNC DELİK	PF10MS ZA3	PF10MD ZA3	855,00
5	22	57.5	10x25	2	ÇOKLU DELİK-CNC DELİK	PF10MS AA3	PF10MD AA3	855,00
6	22	57.5	10x25	2	ÇOKLU DELİK-CNC DELİK	PF10MS BA3	PF10MD BA3	855,00
7	22	57.5	10x25	2	ÇOKLU DELİK-CNC DELİK	PF10MS CA3	PF10MD CA3	910,00
8	22	57.5	10x25	2	ÇOKLU DELİK-CNC DELİK	PF10MS DA3	PF10MD DA3	910,00
10	22	57.5	10x25	2	ÇOKLU DELİK-CNC DELİK	PF10MS EA3	PF10MD EA3	944,00

TAM DELİK MATKAP UÇLARI 70 MM

Makineler:
CNC, delme ve çoklu delme makineleri

Malzemeler: Yumuşak ve sert ağaç, ahşap paneller ve MDF

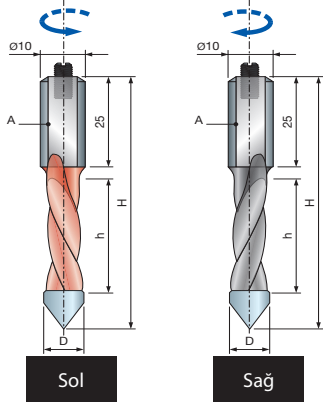

D mm	h mm	H mm	A mm	Z	MAKİNE/AÇIKLAMA	SOL	SAĞ	FİYAT
3	20	70	10x40	2	ÇOKLU DELİK-CNC DELİK	*PF33MS VC3	*PF33MD VC3	999,00
4	27	70	10x30	2	ÇOKLU DELİK-CNC DELİK	*PF33MS ZC3	*PF33MD ZC3	997,00
5	35	70	10x25	2	ÇOKLU DELİK-CNC DELİK	PF10MS AC3	PF10MD AC3	715,00
6	35	70	10x25	2	ÇOKLU DELİK-CNC DELİK	PF10MS BC3	PF10MD BC3	929,00
7	35	70	10x25	2	ÇOKLU DELİK-CNC DELİK	PF10MS CC3	PF10MD CC3	989,00
8	35	70	10x25	2	ÇOKLU DELİK-CNC DELİK	PF10MS DC3	PF10MD DC3	829,00
10	35	70	10x25	2	ÇOKLU DELİK-CNC DELİK	PF10MS EC3	PF10MD EC3	1.051,00
12	35	70	10x25	2	ÇOKLU DELİK-CNC DELİK	PF10MS GC3	PF10MD GC3	1.261,00

* KARBÜR

TAM DELİK MATKAP UÇLARI 70 MM (ÇİFT TALAŞ)

Makineler:
CNC, delme ve çoklu delme makineleri

Malzemeler: Yumuşak ve sert ağaç, ahşap paneller ve MDF

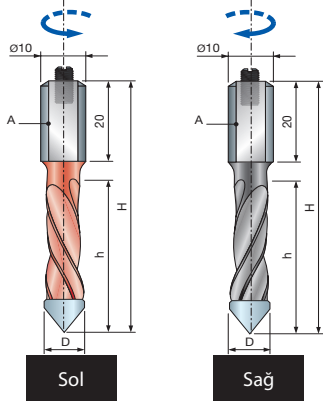

D mm	h mm	H mm	A mm	Z	MAKİNE/AÇIKLAMA	SOL	SAĞ	FİYAT
5	40	70	10X20	2	ÇOKLU DELİK-CNC DELİK	PF11MS AC3	PF11MD AC3	715,00
8	40	70	10X20	2	ÇOKLU DELİK-CNC DELİK	PF11MS DC3	PF11MD DC3	829,00
10	40	70	10X20	2	ÇOKLU DELİK-CNC DELİK	PF11MS FC3	PF11MD FC3	1.051,00

TAS MENTEŞELER 57,5 MM

Makineler:
CNC, delme ve çoklu delme makineleri

Malzemeler: Yumuşak ve sert ağaç, ahşap paneller ve MDF

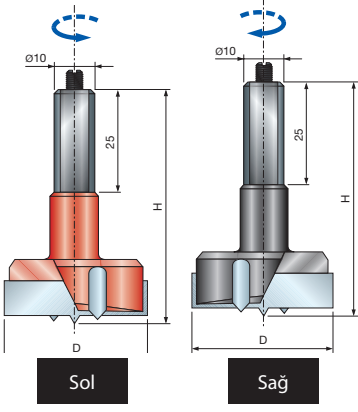

D mm	H mm	A mm	Z mm	MAKİNE/AÇIKLAMA	SOL	SAĞ	FİYAT
15	57.5	10X25	2+2	ÇOKLU DELİK-CNC DELİK	PC04MS 153	PC04MD 153	1.194,00
20	57.5	10X25	2+2	ÇOKLU DELİK-CNC DELİK	PC04MS 203	PC04MD 203	1.338,00
22	57.5	10X25	2+2	ÇOKLU DELİK-CNC DELİK	PC04MS 223	PC04MD 223	1.461,00
25	57.5	10X25	2+2	ÇOKLU DELİK-CNC DELİK	PC04MS 253	PC04MD 253	1.415,00
26	57.5	10X25	2+2	ÇOKLU DELİK-CNC DELİK	PC04MS 263	PC04MD 263	1.505,00
35	57.5	10X25	2+2	ÇOKLU DELİK-CNC DELİK	PC04MS 353	PC04MD 353	1.477,00
40	57.5	10X25	2+2	ÇOKLU DELİK-CNC DELİK	PC04MS 403	PC04MD 403	2.154,00

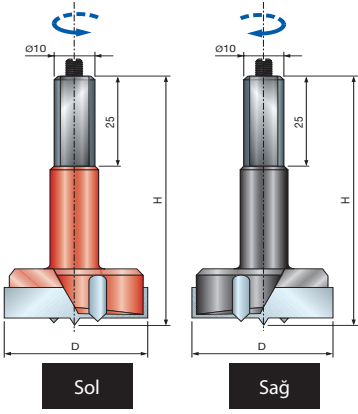

TAS MENTEŞELER 70 MM

Makineler:
CNC, delme ve çoklu delme makineleri

Malzemeler: Yumuşak ve sert ağaç, ahşap paneller ve MDF



D mm	H mm	A mm	Z mm	MAKİNE/AÇIKLAMA	SOL	SAĞ	FİYAT
15	70	10X25	2+2	ÇOKLU DELİK-CNC DELİK	PC05MS 153	PC05MD 153	1.326,00
20	70	10X25	2+2	ÇOKLU DELİK-CNC DELİK	PC05MS 203	PC05MD 203	1.592,00
25	70	10X25	2+2	ÇOKLU DELİK-CNC DELİK	PC05MS 253	PC05MD 253	1.505,00
35	70	10X25	2+2	ÇOKLU DELİK-CNC DELİK	PC05MS 353	PC05MD 353	1.622,00
40	70	10X25	2+2	ÇOKLU DELİK-CNC DELİK	PC05MS 403	PC05MD 403	2.252,00

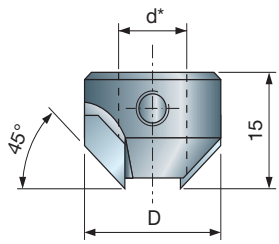

HAVŞALAR

Yan sabitleme vidalı HW uçlu havşa kesiciler

Makineler:
CNC, delme ve çoklu delme makineleri

Malzemeler: Yumuşak ve sert ağaç, ahşap paneller ve MDF



D mm	d mm	H mm	Z mm	MAKİNE/AÇIKLAMA	SOL	SAĞ	FİYAT
16	5	15	2		SV05MS AA3	SV05MD AA3	986,00
18	8	15	2		SV05MS DA3	SV05MD DA3	1.000,00
20	10	15	2		SV05MS FA3	SV05MD FA3	1.015,00

PCD Düz parmak frezeler



D mm	h mm	H mm	A mm	Z	Z°	AÇIKLAMA	ÜRÜN KODU	FİYAT
6	11	60	6	2	-3°	TÜM CNC MAKİNELER	DFG 1E0091	3.985,00
8	14	60	8	2	-3°	TÜM CNC MAKİNELER	DFG 1E0095	4.724,00
8	21	65	8	2	-3°	TÜM CNC MAKİNELER	DFG 1E0096	5.768,00
8	27	70	8	2	-3°	TÜM CNC MAKİNELER	DFG 1E0097	6.289,00
9	14	60	10	2	-3°	TÜM CNC MAKİNELER	DFG 1E0101	5.246,00
9	21	65	10	2	-3°	TÜM CNC MAKİNELER	DFG 1E0102	6.289,00
9	27	70	10	2	-3°	TÜM CNC MAKİNELER	DFG 1E0103	6.289,00
10	14	60	10	2	-3°	TÜM CNC MAKİNELER	DFG 1E0078	5.246,00
10	21	65	10	2	-3°	TÜM CNC MAKİNELER	DFG 1E0079	5.768,00
10	27	70	10	2	-3°	TÜM CNC MAKİNELER	DFG 1E0080	7.347,00
10	33	80	10	2	-3°	TÜM CNC MAKİNELER	DFG 1E0081	7.347,00

D: Kesici ağız çapı
h: Kesim boyu
H: Komple boyu
A: Gireceği pens için şaft çapı
Z: Diş sayısı
Z° : Diş açısı

PCD Parçalı parmak frezeler



D mm	h mm	H mm	A mm	Z	TOT.Z	AÇIKLAMA	ÜRÜN KODU	FİYAT
8	21	70	10	1+1	2+1	TÜM CNC MAKİNELER	DFN 2A0055	3.666,00
8	27	75	10	1+1	3+1	TÜM CNC MAKİNELER	DFN 2A0056	3.666,00
9	21	70	10	1+1	2+1	TÜM CNC MAKİNELER	DFN 2A0057	3.666,00
9	27	75	10	1+1	3+1	TÜM CNC MAKİNELER	DFN 2A0058	3.666,00
10	21	70	10	1+1	2+1	TÜM CNC MAKİNELER	DFN 2A0004	3.666,00
10	27	75	10	1+1	3+1	TÜM CNC MAKİNELER	DFN 2A0005	3.985,00
12	27	75	12	1+1	4+1	TÜM CNC MAKİNELER	DFN 2A0009	4.188,00
12	27	75	12	2+2	6+1	TÜM CNC MAKİNELER	DFN 2A0010	5.449,00
12	21	70	12	3+3	8+1	TÜM CNC MAKİNELER	DFN 2A0006	13.192,00
12	27	75	12	3+3	10+1	TÜM CNC MAKİNELER	DFN 2A0008	15.939,00
12	31,5	80	12	3+3	14+1	TÜM CNC MAKİNELER	DFN 2A0011	17.594,00
12	25	70	12	3+3	12	TÜM CNC MAKİNELER	DFN 2A0007	15.939,00
18	45	105	20	2+2	11+1	TÜM CNC MAKİNELER	DFN 2A0040	9.448,00
18	55	120	20	2+2	13+1	TÜM CNC MAKİNELER	DFN 2A0041	10.868,00
20	61	130	20	2+2	14+1	TÜM CNC MAKİNELER	DFN 2A0043	12.592,00

D: Kesici ağız çapı
h: Kesim boyu
H: Komple boyu
A: Gireceği pens için şaft çapı
Z: Diş dağılımı tipi
TOT.Z : Toplam diş adedi

PCD Radüslü parmak frezeler



D mm	h mm	H mm	A mm	Z	R	AÇIKLAMA	ÜRÜN KODU	FİYAT
12	18,3	70	20	2	2	TÜM CNC MAKİNELER	DFG 9Z0238	7.991,00
12	18,3	70	20	2	3	TÜM CNC MAKİNELER	DFG 9Z0239	7.991,00
12	18,6	70	20	2	4	TÜM CNC MAKİNELER	DFG 9Z0240	7.991,00

D: Kesici ağız çapı
h: Kesim boyu
H: Komple boyu
A: Gireceği pens için şaft çapı
Z: Diş sayısı
R: Radüs ölçüsü

PCD Takmatik Sağ



D mm	h mm	A mm	Z	TOT.Z	Z°	AÇIKLAMA	ÜRÜN KODU	FİYAT
70	50	20	2+2	10	30°	YERLİ TÜM MAKİNELER	DFG 0B0057R	19.795,00
80	45	30	3+3	12	30°	TÖRK, BIESSE	DFG 0B0070R	24.744,00
100	45	30	3+3	15	40°	HOMAG, NANXING, TÖRK	DFG 0B0010R	29.693,00
100	65	30	3+3	18	30°	HOMAG, BIESSE, HOLZHER, IMA	DFG 0B0020R	34.095,00
125	40	30	3+3	15	45°	HOMAG	DFG 0B0030R	29.693,00
125	55	30	3+3	18	40°	HOMAG, NANXING	DFG 0B0041R	30.786,00
125	55	30	3+3	18	40°	TURANLAR, BIESSE, IMA	DFG 0B0042R	30.786,00
125	65	30	3+3	18	30°	KDT	DFG 0B0048R	31.894,00
125	65	30	3+3	18	30°	HOMAG, IMA, NANXING	DFG 0B0047R	31.894,00

PCD Takmatik Sol



D mm	h mm	A mm	Z	TOT.Z	Z°	AÇIKLAMA	ÜRÜN KODU	FİYAT
70	50	20	2+2	10	30°	YERLİ TÜM MAKİNELER	DFG 0B0056L	19.795,00
80	45	30	3+3	12	30°	TÖRK, BIESSE	DFG 0B0069L	24.744,00
100	45	30	3+3	15	40°	HOMAG, NANXING, TÖRK	DFG 0B0009L	29.693,00
100	65	30	3+3	18	30°	HOMAG, BIESSE, HOLZHER, IMA	DFG 0B0019L	34.095,00
125	40	30	3+3	15	45°	HOMAG	DFG 0B0029L	29.693,00
125	55	30	3+3	18	40°	HOMAG, NANXING	DFG 0B0039L	30.786,00
125	55	30	3+3	18	40°	TURANLAR, BIESSE, IMA	DFG 0B0040L	30.786,00
125	65	30	3+3	18	30°	KDT	DFG 0B0048L	31.894,00
125	65	30	3+3	18	30°	HOMAG, IMA, NANXING	DFG 0B0047L	31.894,00

D: Kesici ağız çapı
h: Dişten dış kesim yüksekliği
A: gireceği mil için göbek ölçüsü
Z: Diş dağılımı tipi
Z°: Diş açısı

PCD Panel Ebatlama Testereleri



D mm	B mm	b mm	d mm	Z	H	NL	AÇIKLAMA	ÜRÜN KODU	FİYAT
300	3,2	2,2	30	72	6	2/7/42, 2/9/46,4, 2/10/60	TÜM YATAR MAKİNELER	PFZ P00063	31.487,00
300	3,2	2,2	30	96	6	2/7/42, 2/9/46,4, 2/10/60	TÜM YATAR MAKİNELER	PCN PM0030	36.747,00
320	4,4	3,2	65	72	6	2/9/110	SELCO	PFZ P00126	47.238,00
320	4,4	3,2	75	72	6	3/7/100	TÖRK	PFZ P00136	47.238,00
360	4,4	3,2	65	72	6	2/9/110	SELCO	PFZ P00208	47.238,00
380	4,4	3,2	60	72	6	2/14/100	HOLZMA	PFZ P00213	47.238,00
380	4,8	3,6	60	84	6	2/14/100	HOLZMA	PFZ P00222	49.875,00
400	4,4	3,2	75	72	6	2/7/110	KDT SAWTECH	PFZ P00243	47.238,00
400	4,4	3,2	80	72	6	2/14/110	GABBIANNI	PFZ P00254	47.238,00
430	4,4	3,2	65	84	6	2/9/110	SELCO	PFZ P00265	47.238,00
430	4,4	3,2	75	84	6	2/7/110	KDT SAWTECH	PFZ P00268	47.238,00
450	4,8	3,6	60	84	6	2/14/125	HOLZMA	PFZ P00275	49.875,00
450	4,8	3,6	75	84	6	2/7/110	KDT SAWTECH	PFZ P00288	49.875,00
470	4,8	3,6	70	84	6	4/11/130	SELCO	PFZ P00293	49.875,00

PCD Panel Ebatlama Çizicileri



D mm	B mm	b mm	d mm	Z	H	NL	AÇIKLAMA	ÜRÜN KODU	FİYAT
125	3,0	2,2	20	24	6		TÜM YATAR MAKİNELER	PFZ Z00027	17.996,00
160	4,3	3,2	55	36	6		TÖRK	PFZ C00051	19.997,00
180	4,3	3,2	45	36	6		HOLZMA	PCN CC0111	19.997,00
180	4,7	3,6	45	36	6		HOLZMA	PCN CC0120	24.992,00
200	4,3	3,2	50	36	6	2/7/80	KDT SAWTECH	PFZ C00108	19.997,00
200	4,3	3,2	65	36	6	2/9/100, 2/9/110	SELCO	PFZ C00121	19.997,00
200	4,3	3,2	80	36	6	2/14/110	GABBIANNI	PFZ C00137	19.997,00
200	4,7	3,6	45	36	6		HOLZMA	PFZC00169	24.992,00
200	4,7	3,6	50	36	6	2/7/80	KDT SAWTECH	PFZ C00114	24.992,00
200	4,7	3,6	65	36	6	2/9/100, 2/9/110	SELCO	PFZ C00133	24.992,00
215	4,3	3,2	50	36	6	2/7/80	KDT SAWTECH	PFZ C00145	24.992,00

D: Testere çapı
B: Kesim genişliği
b: Gövde genişliği
d: Göbek çapı
Z: Diş sayısı
H: Diş yüksekliği

Alüminyum Testereleri



D mm	B mm	b mm	d mm	Z	NL	AÇIKLAMA	ÜRÜN KODU	FİYAT
355	2,2	1,8	40	48	4/11/63	ROHBİ	TFN L00039	8.280,00
355	2,2	1,8	40	96	4/11/63	ROHBİ	TFN L00108	10.350,00
355	3,2	2,6	25,4	120		JIH-I	TCN LE0030	9.384,00
380	3,8	3,2	32	56		ELUMATEC	TFZ L00132	9.509,00
380	3,8	3,2	32	96		ELUMATEC	TFZ L00133	10.533,00
405	3,5	2,8	25,4	120		JIH-I	TFN L00110	10.690,00
405	3,5	2,8	30	120	2/11/63	SCHTEC, DECALUMA	TFN L00111	10.690,00
420	4,0	3,2	30	96		ELUMATEC	TFZ L00165	12.069,00
420	3,5	2,8	25,4	120		JIH-I	TFZ L00337	12.100,00
420	3,5	2,8	30	120	2/11/63	EMMEGI, MECAL, ELUMATEC	TFZ L00338	12.100,00
450	3,4	2,6	25,4	72		JIH-I	TFZ L00339	12.006,00
450	3,4	2,6	30	72	2/11/63	ÖZGENÇ, YILMAZ, ÖZÇELİK	TFZ L00340	12.006,00
450	3,0	2,5	25,4	120		JIH-I	TFZ L00170	12.434,00
450	3,0	2,5	30	120	2/11/63	ELUMATEC, MECAL, EMMEGI	TFZ L00336	12.434,00
500	4,2	3,4	30	72		ELUMATEC, MECAL, EMMEGI	AC5325	15.870,00
500	4,2	3,2	25,4	84		JIH-I	TFZ L00194	17.664,00
500	4,2	3,4	30	96	2/11/63	ELUMATEC, MECAL, EMMEGI	TFZ L00204	16.560,00
500	3,5	3,0	30	120	2/11/70	ELUMATEC, MECAL, EMMEGI	TFZ L00197	20.286,00
500	4,4	3,8	25,4	120		JIH-I	TFZ L00196	19.044,00
500	4,4	3,8	30	120	2/11/63, 2/11/70	ELUMATEC, MECAL, EMMEGI	TFZ L00331	19.044,00
550	4,4	3,8	30	72		ELUMATEC, MECAL, EMMEGI	AC5326	19.320,00
550	3,5	3,0	30	120	2/11/70	ELUMATEC, MECAL, EMMEGI	TFZ L00246	21.390,00
550	4,6	4,0	30	96	2/11/63, 2/11/70	ELUMATEC, MECAL, EMMEGI	TFZ L00255	18.285,00
550	4,6	4,0	25,4	120		JIH-I	TFZ L00245	20.919,00
550	4,6	4,0	30	120	2/11/70	ELUMATEC, MECAL, EMMEGI	TFZ L00243	20.919,00
600	4,6	3,4	25,4	84		JIH-I	TFZ L00268	25.068,00
600	4,8	4,2	30	96	2/11/70	ELUMATEC, MECAL, EMMEGI,FOM	TFZ L00274	25.530,00
600	4,8	4,0	25,4	140		JIH-I	TFZ L00269	27.738,00
600	4,8	4,0	30	140	2/11/63, 2/11/70	ELUMATEC, MECAL, EMMEGI,FOM	TFZ L00334	27.738,00
650	4,6	3,4	25,4	84		JIH-I	AQ6117	28.290,00
650	5,0	4,0	25,4	140	2/11/70	JIH-I	TFZ L00287	31.444,00
660	5,0	4,0	25,4	120	2/11/70	JIH-I	TFZ L00335	31.200,00
700	5,0	4,0	30	96		SİSTEM, OMAV, KAUTEC	TFN L00093	35.211,00
700	5,0	4,0	30	120		SİSTEM, OMAV, KAUTEC	AC7061	35.190,00
700	5,0	4,0	38	120		YILMAZ, İNTEL, ATECH	AC7028	34.914,00
700	5,0	4,0	50	120		SİSTEM, OMAV, KAUTEC	AC7068	34.638,00
750	5,5	4,5	30	140	4/18/150	SİSTEM, OMAV, KAUTEC	TFZ L00304	39.123,00
750	5,0	4,0	30	220	4/18/150	SİSTEM, OMAV, KAUTEC	TFZ L00303	44.195,00
800	7,0	5,5	40	64		SİSTEM, OMAV, KAUTEC	TFN L00099	60.720,00
800	6,5	5,5	40	72		SİSTEM, OMAV, KAUTEC	TFN L00097	64.170,00
800	6,5	5,5	40	96		SİSTEM, OMAV, KAUTEC	TFN L00098	60.858,00
800	6,5	5,5	40	140		SİSTEM, OMAV, KAUTEC	TFN L00096	64.170,00
900	6,5	5,5	40	64		SİSTEM, OMAV, KAUTEC	TFN L00102	78.660,00
910	6,5	5,5	40	100		SİSTEM, OMAV, KAUTEC	TFN L00103	84.180,00
910	6,5	5,5	40	120		SİSTEM, OMAV, KAUTEC	TFN L00104	85.560,00
910	6,5	5,5	40	160		SİSTEM, OMAV, KAUTEC	TFN L00105	88.320,00
965	7,0	5,5	50	120	2/27/89.80	JIH-I	TFNL00109	87.900,00
1000	6,5	5,5	40	64		SİSTEM, OMAV, KAUTEC	TFN L00002	88.320,00
1000	7,0	5,5	50	120		SİSTEM, OMAV, KAUTEC	TFN L00003	92.460,00
1000	7,0	5,5	50	140		SİSTEM, OMAV, KAUTEC	TFN L00004	103.500,00
1000	7,0	5,5	50	160		SİSTEM, OMAV, KAUTEC	TFN L00005	105.570,00
1000	7,0	5,5	50	180		SİSTEM, OMAV, KAUTEC	TFN L00006	110.262,00

D: Testere çapı
B: Kesim genişliği
b: Gövde genişliği
d: Göbek çapı
Z: Diş sayısı



ÖZDOĞAN HIRDAVAT SAN.TİC.LTD.ŞTİ
ADRES : (EŞBAH-İPEKYOLU) MEHMET AKİF MH. BAHARİYE CD. NO:161
B1 KATI - İÇ KAPI NO : 16

KÜÇÜKÇEKMECE - İSTANBUL

TELEFON: 0212 222 57 25 FAX: 0212 320 28 79

Self&Inn®

www.ozdoganhirdavat.com

I-ZET®

info@ozdoganhirdavat.com